

Agilent IrDA Data Link Design Guide

Introduction

Welcome to the World of Infrared Data Communications! This guide is designed to provide you with the background necessary to design and implement your very own IrDA compatible data link. Within these pages, you will find detailed information on all phases of the design process, from architectural considerations through board layout. You will also learn about the Infrared Data Association (IrDA) — about its purpose, and about the IrDA specification for IR data transfer.

In addition, a selection guide of Agilent's infrared components has been included. More information is available from the sources listed in the References. In particular, be sure to check the Agilent IR website where you will find the most recent data sheets and application notes.



References

Agilent Technologies, Semiconductor Products Group Sales Offices and Authorized Distributors, Product Data Sheets, Application Notes	http://www.agilent.com/view/ir
HP JetSend Information	http://www.jetsend.hp.com/
Infrared Data Association (IrDA)	http://www.irda.org/
Support Hardware and Software	
Actisys Corp.	http://www.actisys.com/
Extended Systems, Inc.	http://www.extendsys.com/
inSilicon Corporation	http://www.insilicon.com
Link Evolution Corporation	http://www.linkevolution.com
Motorola, Inc.	http://www.motorola.com/
National Semiconductor	http://www.nsc.com/
Okaya SystemWare Co., Ltd.	http://www.okaya-system.co.jp/ (Japanese) http://www.osw.co.jp/index-e.htm (English)
Parallax Systems	http://www.parallax.com/
Phoenix Technologies, Inc.	http://www.phoenix.com http://www.ptltd.com
Puma Technology, Inc.	http://www.pumatech.com/
Standard Microsystems	http://www.smc.com/
VLSI Technology	http://www.vlsi.com/

Table of Contents

References	2
1. Introduction	5
HP/Agilent IR History	5
About This Guide	6
2. IrDA Applications in the Market	7
2.1 Computing Segment	7
PDAs/HandHeld Computers	7
2.2 Telecom	7
2.3 Consumer Electronics	8
Digital Cameras	8
Scanners	8
Toys and Games	8
2.4 Peripherals	8
Printers	8
Infrared Keyboards and Mouse	9
Dongle	9
Port Replicator/LAN Access	9
3. IrDA Standards	11
3.1 Background	11
3.2 Hewlett-Packard Patent Agreement	11
3.3 The IrDA Specifications	11
Overview	11
The IrDA Datalink Protocols	11
3.4 IrPHY - IrDA Physical Layer	12
Overview	12
1.152 kbps and 576 Mbps Data Rate	13
4 Mbps Data Rate	13
Key Physical Layer Parameters	15
Optical Requirements	15
Low Power Option	15
Half Duplex and Latency	17
Ambient Light	17
3.5 IrLAP - Link Access Protocol	17
3.6 IrLMP Protocol	17
3.7 IrCOMM Protocol	19
3.8 IrTRANP	20
3.9 IrMC	21
3.10 IrOBEX (IrDA Object Exchange Protocol)	22
3.11 Software Support	22
4. IrDA Future Directions	23
4.1 Very Fast IR (VFIR)	23

(continues)

Table of Contents (continued)

5. Agilent Products	25
5.1 Introduction	25
5.2 Integrated Transceiver Modules	25
5.3 Endecs (Encoders / Decoders)	27
5.4 Discrete Emitters and Detectors	28
6. Architecture Options for IrDA Data	29
6.1 Typical Architecture	29
6.2 2.4 kbps to 115.2 kbps Super I/O	30
6.3 2.4 kbps to 4 Mbps Super I/O	31
6.4 16550-type UART, Microcontroller or Embedded I/O with 16x Clock	31
6.5 UART, Microcontroller or Embedded I/O without Clock	32
6.6 Interface to RS-232 Port	33
6.7 I/O _{VCC} Interfacing with Low Voltage ASICs	33
6.8 Interfacing for Adaptive Power Management	33
6.9 Serial Transceiver Control	35
6.10 Command Format	35
6.11 Bus Timing	38
7. Design Guidelines	
7.1 Mechanical Considerations	39
7.2 Electrical Considerations	47
7.3 Optical Port Design	51
7.4 Eye Safety	53
8. Evaluation and Developer Kits	55
Evaluation Boards to interface to Super I/O, UARTs or Serial Port	
9. Beyond IrDA	57
9.1 Extending Transmission Distance	57
9.2 Remote Control Application	59
10. Companion Circuits	61
10.1 LED Driver Circuits	61
10.2 Receiver Circuits	61
10.3 Echo Cancellation Circuit	63
Appendix	65

1. Introduction

HP/Agilent IR History

Hewlett-Packard has been offering infrared wireless connectivity in its products since 1979. The infrared discretes once embedded in the HP-41C pocket calculator and HP-48SX calculator have evolved into transceivers commonly found in HP's PDAs, Omnibooks, Printers and many other non-HP products. HP has been incessantly investing in research and development in the infrared technologies to enable mobile products to communicate in a seamless manner.

In 1993, the first HP transceiver module was introduced. The HSDL-1000 enabled Infrared data transmission and reception in a single integrated module. Adhering to the IrDA 1.0 industry standards, the HSDL-1000 is also known as a Serial Infrared (SIR) transceiver. The IrDA 1.0 standard was designed around a "point and shoot" environment for short distance (1m) tether-less communication.

In 1995, the HSDL-1001 and HSDL-1100 were introduced. The former, a direct replacement for the HSDL-1000, enables a wider scope of IR implementation, e.g. input voltage of 3 - 5 V.

The HSDL-1100 provides 4 Mbps Fast Infrared (FIR) capability (as compared to the SIR 115 kbps data rate). This module enables faster communications in printers and notebooks, and is still a much sought after module.

In 1997, the HSDL-2100 and HSDL-2300 were the answers for products facing size reduction pressures. Standing at 5.3 mm, these IR products operate at 5 V

and 3 V respectively. Both transceivers are FIR capable, compliant with IrDA Version 1.1 industry standards. The HSDL-2300 was one of the winners of the 1998 Wireless Design and Development Technology Awards. Designed for data communications applications, the HSDL-2300 transceiver offers end users the benefit of longer battery life in portable devices.

In 1998, a new platform of IR transceivers was born. Using a new castellation technology and improved electronics, Hewlett-Packard was able to bring the cost, power consumption and size of the transceivers to new "lows." With lower cost, lower power consumption and even smaller size, this platform of modules brings wireless connectivity to the telecom world, and the many other products, where the requirements are small size and very low power consumption. Hewlett-Packard was proud to offer the HSDL-3201, HSDL-3600 and HSDL-3610. These products enable Infrared communication in even smaller and slimmer products.

In 1999, HP grouped its test and measurement, semiconductor products, healthcare solutions and chemical analysis businesses together and spun it off as a separate company, Agilent Technologies, as part of a corporate re-alignment process. The IR business unit being a part of the semiconductor products group, became part of Agilent Technologies.

In 2000, under the new company name, yet another world's first was added to its record books with the release of HSDL-3202. The HSDL-3202 is the first transceiver to be able to interface with logic levels as low as 1.8 V. The HSDL-3210 extended the feat of the HSDL-3202 to a higher data rate of 1.152 Mbps in the industry's smallest package, another world's first. The HSDL-3310 is the world's first 1.152 Mbps transceiver to interface with 1.8 V logic levels. Agilent has also cooperatively worked with *inSilicon Corporation* to develop the first semiconductor intellectual property VFIR controller core. The controller supports the VFIR standard of transmission data at 16 Mbps. These developments were in response to the advancements in mobile devices, which are heading toward developing low voltage and high speed applications.

As we enter the new millenium, Agilent continues to introduce new and exciting Infrared products for wireless communications. Join us as we lead in new highs in performance, and new lows for cost, size and power consumption.

About This Guide

This guide is designed to provide the information necessary to design and implement an IrDA compatible data link. An introduction to the IrDA and its standards is included for those new to the technology. This also serves as an update for developers in the Infrared field. Within these pages you will find detailed information for all phases of the design process, ranging from architectural considerations through board layouts to optical considerations. You will also learn about the IrDA, its standards and how they relate to IR communication. In addition, a selection guide is accessible for all users to get acquainted with the offerings of Agilent's infrared components.

For more information, check out the Agilent IR website. Other websites, services and contacts are listed in the *References* section.

2. IrDA Applications in the Market

Networking, interoperability and cable-less technology have graduated from just being buzzwords to reality. Following this evolution in cable-less communications, infrared has experienced enormous growth in the past half-decade due to ease of use and low implementation cost. The Infrared Data Association (IrDA) has projected a total shipment of 1.3 billion units by the year 2003. This high IR adoption rate reflects the presence of more IR applications in the marketplace than ever before, with penetration rate for some segments reaching 100%. Listed below are some of the many possible applications where IR has successfully embedded itself.

2.1 COMPUTING SEGMENT

Two main markets that make up this segment are the Portable/Desktop computing and Handheld markets.

Portable and Desktop Computing

This market segment, comprised of notebooks and sub-notebooks, boasts of having the highest infrared data link penetration rate. Most portable computers in this category have infrared links and the vast majority of them are equipped with 4 Mbps transceivers. With a penetration rate approaching 100%, further market growth of IR will most likely track the growth of the notebook market. Market analysts forecasted that the notebook sector would have a unit growth of over 18% over the next five years. Factors contributing to the wide acceptance and success include low-cost, small size, interoperability with super I/O controllers, ease of use and full OS support (from Microsoft).

Due to architectural constraints, the adoption of IR in the desktop segment has been relatively low. Current desktop designs in the marketplace are more appropriate for placing the desktop in a cabinet or on the floor. However, such a layout is not conducive for any type of point and shoot application profile. To overcome this constraint, IR dongles are available which can be connected to the serial port. Utilizing IR dongles improves user mobility and also allows further upgrades of existing ports.

Success in this market will therefore be determined by the availability of IR adapters and the maximum data rate supported. Currently, the data rate of IR adapters is limited to the maximum data rate of the serial port. With the emergence of Universal Serial Bus (USB) ports, higher speed of 4 Mbps (supported by infrared) could be exploited.

Handheld Devices

The demand for handheld devices, comprised of PDAs (Personal Digital Assistants) and handheld PCs, has grown significantly since 1997. Triggered by the need for mobile access for personal and professional data, most handheld devices today utilize Infrared (IrDA) connectivity to perform data transfer.

Using Infrared connectivity allows PDAs to perform several tasks. Some of the existing IR applications include data exchange with a desktop or notebook PC, electronic business card exchange with another handheld device, and data printing to an IR printer, just to name a few.

The trend toward smaller handheld devices loaded with

multimedia applications requiring higher data rates necessitates a need for faster infrared (4 Mbps and above) transceivers with lower power consumption and smaller form factor. Industry analysts predict that the IR adoption rate in this segment will continue to grow in the next few years.

2.2 TELECOM

The telecommunications market for IrDA applications refers to the mobile phone sector. The IR adoption rate has surged since 1997, when the first mobile phone equipped with IR functionality was launched.

The future of IR in mobile phones is more promising as the liberalization of the global telecommunication industry continues. Industry analysts believe that future mobile phones will have more functions and services, and can potentially overtake fixed line phones. IR plays a vital part in realizing this digital convergence by enabling the phone to "talk" to other network devices such as notebooks, PCs, PDAs and printers.

Two factors governing the success of IR in this market are low power consumption and high data transfer rate. Traditional SIR (Serial Infrared, 115 Kb/s) transceivers are deemed slow in coping with mobile phone services such as imaging applications and internet through Wireless Application Protocol (WAP) or Mobile Media Mode (MMM). Higher infrared speeds of 1 Mbps (Medium Infrared, MIR), 4 Mbps (Fast Infrared, FIR) and 16 Mbps (Very Fast Infrared, VFIR) under-development) will be able to cope with such market needs.

Two crucial factors that mobile phone makers consider when implementing IR into their phones are power consumption and size. The current trend is toward smaller phones, which could improve user portability. The IR transceivers used will therefore need to be small. Smaller transceivers imply lower power usage and indirectly shorter link distances.

Some new developments in this market include the incorporation of features of personal digital assistants (PDAs) into the mobile device. The resulting need for higher speeds from this marriage between data and voice will be addressed by future 16 Mbps transceivers.

2.3 CONSUMER ELECTRONICS

This sector is comprised of digital cameras, scanners, toys and games.

Digital Cameras

This market has evolved from the traditional film-based photography to digital photography. According to Info Trends Research Group, Inc., a leading market research firm, the digital camera market is predicted to expand to 5 million units in 2002 from 1.3 million units in 1998. Rapidly moving toward higher resolution image sensors, the digital cameras in today's market are equipped with 3.5 million pixels.

A market research analyst with InfoTrends commented that the huge growth of the digital camera market is attributed to increasing penetration of personal computers, Internet connectivity, mass market awareness and digital photo retail and online services.

Factors that will affect IR adoption rate in this market include IR transceiver size, speed and power consumption. The Current Infrared speed of 4 Mbps is sufficient to allow fast transmission of files via the IR port to desktops. Future speed of 16 Mbps will be able to address the needs of digital cameras with higher resolution.

Scanners

Infrared adoption rate in portable scanners is faster and higher in comparison to office scanners. Portable scanners utilizing IR allow the user to transfer and print scanned images to other computing peripherals such as desktops and printers. This requires a minimum infrared speed of 4 Mbps (FIR). Faster infrared speed of 16 Mbps, currently under development, will be able to address future needs for faster data transmission.

The key factors of portable scanners are portability and power which are indirectly determined by the size and power consumption. The IR transceiver used therefore needs to be small in size, consume low power and be able to transmit data at a fast rate.

Toys and Games

Another application of IR is in the game arena where a device beams across trading items, custom characters and configurations to another device. One such example is the Nintendo Game Boy Color™. Another application is known as the intelligent toy where games, programs, songs and stories can be downloaded from a desktop through an IR dongle. Infrared speed of 115 Kb/s (SIR) is sufficient to allow such data transfer since the file size is relatively small.

Toy manufacturers have also designed toys that allow children to beam messages to each other using IR. Examples of manufacturers include Radica Games™ and Tiger Electronics™.

2.4 PERIPHERALS

Infrared technology also addresses the need for wireless communication of the peripherals market such as the printers, keyboard and mouse, dongle and port replicator/LAN access.

Printers

The printer market is largely driven by the growth of personal computers and printers.

Hewlett-Packard, the leader in the printer market, has also been a leader in adopting IR in its printers. Introducing IR links in its 5P series of personal laser printers in 1997, HP has also adopted IR in its portable inkjet printers in 1997.

IR port can be implemented onto a printer either by embedding onto the printer itself or via an external IR adapter. The connection for the IR adapter (dongle) can be done easily through a serial or parallel port, as it creates greater flexibility in the placement of the IR port. Any user simply needs to perform the "point and shoot" action by aligning the handheld or data device to the printer IR port. This entire process, accomplished within seconds in the absence of wires, is time efficient and improves user mobility.

The wide proliferation of IR in this market has encouraged more OEMs (Original Equipment Manufacturers) to incorporate IR port into their printers. Success factors of IR in this market include speed and the angle at which beaming is

possible. This is because higher data rate for faster printing is required for image printouts with megabyte files, and a wider beaming angle improves user mobility.

Infrared Keyboards and Mouse

Users enjoy greater mobility with the convenience of locating and operating their keyboard and mouse in the absence of wires. One application is in the set-top box or interactive television where an infrared keyboard is aligned with a wireless keyboard receiver. The receiver is connected to the television, allowing the user to browse the web in comfort from any room in the house. The television could also be connected to a desktop, enabling the user to save any information.

Dongle

An IrDA PC dongle enables IR-capable portable devices such as notebooks, digital cameras, handheld devices, and mobile phone users to conveniently transfer files back and forth to a desktop PC in the absence of wires.

The recent release of an IrDA dongle that connects to the widely popular Universal Serial Bus (USB) port and plug-n-play support by Windows 2000 would dramatically increase the IR adoption rate in desktop applications. According to In-Stat Group, a market research firm, 750 million desktop and notebook PCs will be USB-equipped in 2004. The IrDA-USB dongle would allow users to transfer and synchronize files conveniently between desktop and any portable device at FIR speeds of 4 Mbps.

Port Replicator/ LAN Access

The port replicator is a device that enables notebook and handheld device users to instantly access printer, mouse, keyboard, and network across a universal infrared connection without the problems of cable. Future IrDA standard of 16 Mb/s will allow users to experience the real throughput of 10 Mbps Ethernet speed when using the port replicator to access a network.

3. IrDA Standards

This section presents an overview of IrDA, and the features and requirements of IrDA compliant products.

3.1 IrDA BACKGROUND

The IrDA is an independent organization whose charter is to create interoperable, low cost IR Data interconnection standards that support a walk up, point-to-point user model that is adaptable to a broad range of appliances, such as computing and communicating devices. The following are the fees associated with IrDA membership.

IrDA Membership Fees:

- US \$8,000 for executive membership (same as affiliate, plus voting rights)
- US \$4,000 for affiliate membership, if applicant's gross annual revenue is equal to or greater than \$250,000 (standards documents, attend meetings, access to e-mail reflector/ mailing list)
- US \$1,500 for affiliate membership, if applicant's gross annual revenue is equal to or greater than \$250,000 (standards documents, attend meetings, access to e-mail reflector/ mailing list)

IrDA Standards Document Fee:

- US \$500 per company, for Standards Documents

3.2 HEWLETT-PACKARD PATENT AGREEMENT

Hewlett-Packard has a patent on the Serial IR (SIR) encode/decode circuitry and IR receiver (minus the PIN photodiode) (Figure 3.3). This is the basis of the HP SIR Technology. Components or sub-system manufacturers who provide, or intend to provide, components that infringe on HP's patent should consider acquiring a patent license from the licensing agent, IrDA. System manufactur-

ers or OEMs that purchase and implement components utilizing the technology do not need to acquire a Hewlett-Packard patent license. The system OEM is relieved of any license requirement as long as one of the components in the system is from a firm that acquired a valid HP License fee of \$5000. Hewlett-Packard's patent only applies to the 115.2 kbps IrDA 1.0 standard. License agreements are not required for any higher speed versions, such as the 1.15 Mbps and 4 Mbps standard.

3.3 THE IrDA SPECIFICATIONS

This section presents an overview of the IrDA, and the features and requirements of IrDA compliant products.

Overview

The Infrared Data Association (IrDA) is an independent organization whose charter is to create standards for interoperable, low cost IR data interconnection. Setting standards for IR communication is key to effortless communication between various types and brands of equipment. It is the goal of IrDA to set standards and protocols, which can be reasonably and inexpensively implemented in order to promote the proliferation of IR communication. The first version of the IrDA data link Physical Layer Specification (IrPHY) 1.0, provided for communication at data rates up to 115.2 kbps. Version 1.1 extended the data rate to 4 Mbps, while maintaining backward compatibility with Version 1.0 products. Version 1.2 defined a low power option for data transmission speed up to 115.2 kbps. Version 1.3 extended the low power option operation to 1.152 Mbps and 4 Mbps.

Without a communication protocol, such as that provided by IrDA, a non-cabled link is inherently not robust. Unlike a cable, which is semi-permanently attached, the ends of an IR link may move freely in and out of range. The link may even be broken in the middle of a transmission. IrDA defines a set of specifications, or protocol stack, that provides for the establishment and maintenance of a link so that error free communication is possible. The IrDA Standards include three mandatory specifications: the Physical Layer, Link Access Protocol (IrLAP), and Link Management Protocol (IrLMP).

While the primary focus of this guide is the implementation of the Physical Layer, we will start with a brief overview of the software protocols. Further information about IrDA, as well as the specifications themselves, are available from IrDA (see Contacts)

Note that each successive revision supercedes the previous. Also, while a new revision provides for additional options, it does not mean that the device has to meet it. For example, while IrPHY 1.3 supports 4 Mbps at low power, it does not mean that an IrPHY 1.3 compliant device has to support 4 Mbps at low power.

The IrDA Datalink Protocols

The IrDA Datalink Protocols are organized as a series of layers, each built upon the one below it, with the lowest layer being the physical layer. They may be visualized as a protocol stack. The function of each layer is to offer certain services to the next upper layer, shielding those layers from the details of how the offered services are actually being implemented. The three manda-

tory layers as mentioned above are the Physical Layer (IrPHY), Link Access layer (IrLAP), and the Link Management layer (IrLMP). A typical implementation of the IrDA protocol stack within an operating system is shown in Figure 3.1.

3.4 IrPHY – IrDA PHYSICAL LAYER

Overview

The Physical Layer Specification provides guidelines for point-to-point communication between equipment using IR. The current specification (Version 1.3) supports the standard power and low power option. The standard power option ensures error free communication from a distance of 0 to 100 cm, at an off axis angle of 0 to at least 15° (Figure 3.2). The low power option, intended for handheld devices and the telecommunication industry, ensures error free transmission from 0 to 20 cm, at an off angle of 0 to at least 15°. Included are specifications for modulation, viewing angle, optical power, data rate, and noise immunity in order to guarantee physical interconnectivity between various brands and types of equipment. The specifications also ensure successful communication in typical environments where ambient light or other IR noise sources may be present, and minimize interference between IR participants.

The specifications for optical intensity for the transmitter and sensitivity for the receiver were chosen to guarantee that the link will work from 0 to 100 cm for standard power devices, and 0 to 20 cm for low power option devices. The receiver sensitivity was chosen so that a minimum inten-

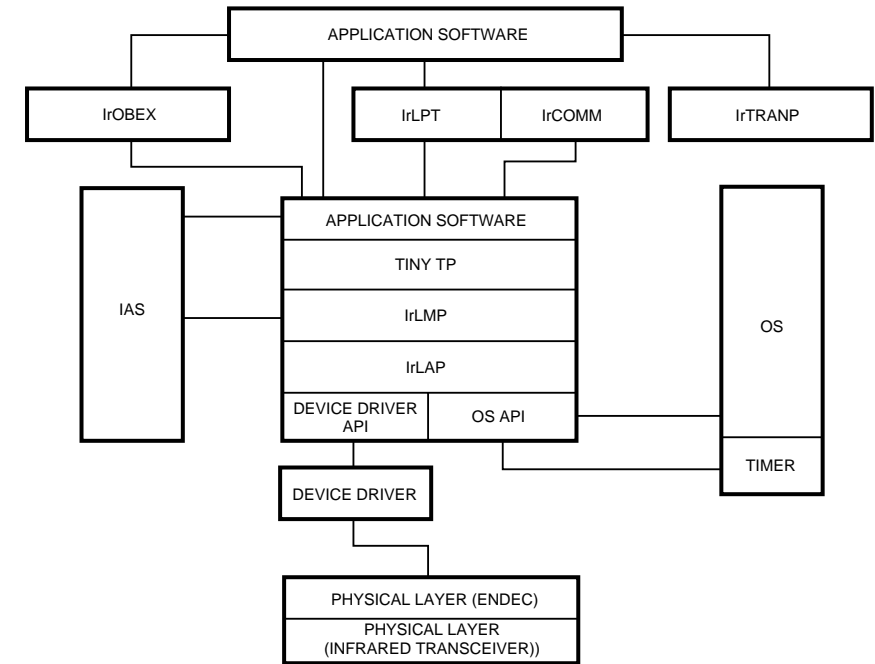

Figure 3.1. Example of a Typical IrDA Implementation in an Operating System.

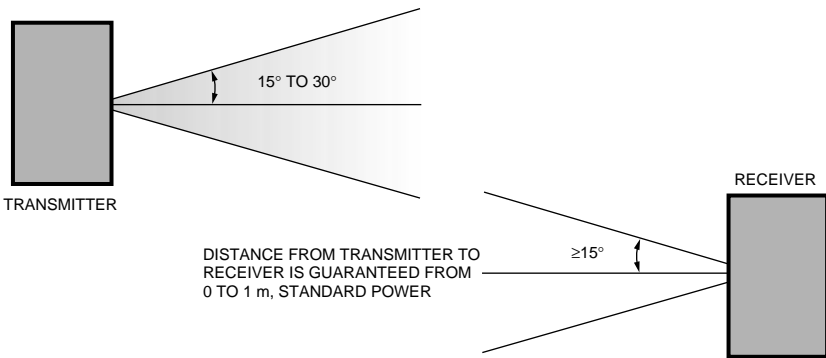

Figure 3.2. IrDA Physical Layer Viewing Angle and Distance.

sity emitter will guarantee the minimum link distance as specified.

Figure 3.3 shows a block diagram of the physical layer for data rates up to 115.2 kbps. This was conceived as a link that would work readily with conventional UARTs, such as the NS 16550. Thus it is a straightforward extension of the serial port. Note in Figure 3.3, however, that the data is first en-

coded before being transmitted as IR pulses. This is required because UARTs and serial ports use NRZ (non-return to zero) coding where the output is the same level for the entire bit period and can stay at one level for multiple bit periods. This is seen in Figure 3.4 as the data labeled “UART frame.” This is not optimal for IR data transfer since a continuous string of bits could turn on the LED transmitter for an arbitrarily

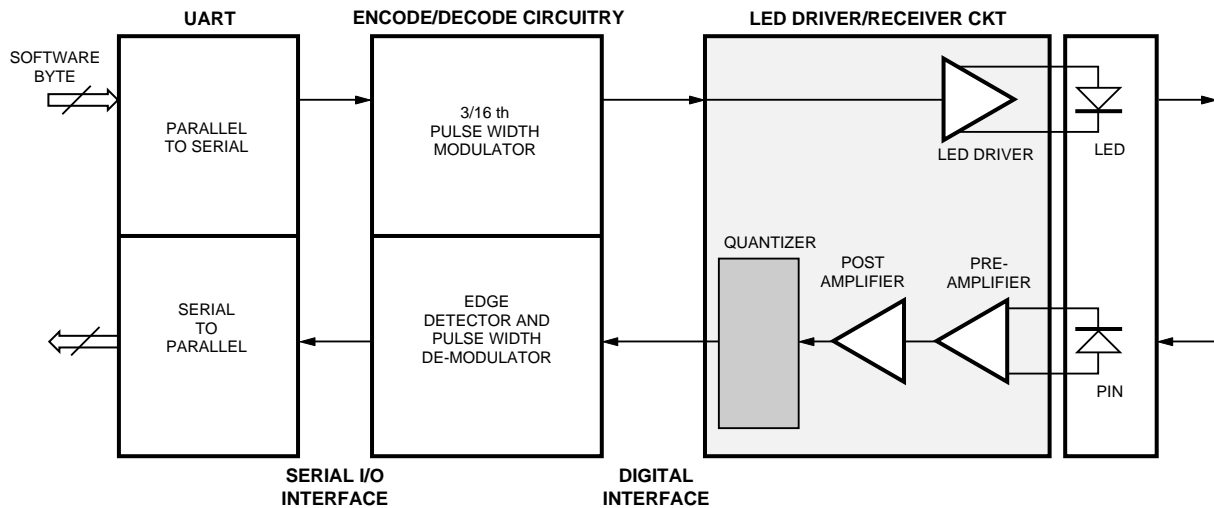

Figure 3.3. IrDA Version 1.0 Physical Block Diagram.

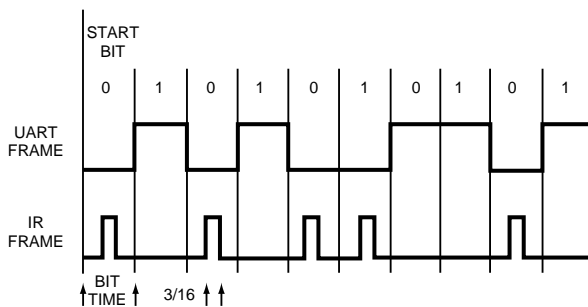

Figure 3.4. IrDA 3/16 Data Modulation.

long time. Thus the power in the LED would need to be limited, which would then limit the working distance. Instead, the IrDA standard requires pulsing the LED in a RZI (return to zero, inverted) modulation scheme so that the peak to average power ratio can be increased. The maximum pulse width is required to be 3/16 of the bit period. The minimum pulse width can be as little as 1.41 μ s, which is derived from 3/16 of the highest data rate of 115.2 kbps. The effect of the encoding can be seen in Figure 3.4 as the data labeled “IR Frame.” A 16x clock is conveniently available on many UARTs, so it is easy to count three clock cycles to encode the transmitted data, and to stretch the received data with 16 clock cycles. Note that this scheme re-

quires an encoder/decoder (endec), either embedded in the I/O chip or as a discrete component. This will be discussed further in the following sections.

1.152 kbps and 576 Mbps Data Rate

The IrDA Physical Layer Specifications also support the intermediate data rates of 576 kbps and 1.152 Mbps. These speeds use an RZI modulation similar to the 3/16 modulation used at 115.2 kbps and slower, but use a nominal 25% pulse width.

4 Mbps Data Rate

Beginning with Version 1.1 of the IrDA physical layer specification, a 4 Mbps data rate is supported. The IrLAP specification requires all links to begin negotiation at 9.6 kbps and then negotiate to

higher data rates, if supported at both ends. Therefore all devices that support a 4 Mbps data rate will have to be capable of supporting a lower data rate of 9.6 kbps at the minimum. Thus a 4 Mbps device will be able to communicate with a device that only supports 9.6 kbps. This ensures backward compatibility.

A 4 Mbps IrDA link uses a modulation scheme known as 4 PPM (Pulse Position Modulation), instead of the 3/16 modulation used for slower data rates. With 4 PPM, information is conveyed by the position of a pulse within a time slot. In the 4 PPM scheme (Figure 3.5) two data bits are combined to form a 500 ns “data bit pair” (DBP). This DBP is divided into four 125 ns time slots or “chips”. The two bits to be encoded will have one of four states 00, 01, 10, 11. Depending upon which of these states is present, a single pulse is placed in either the first,

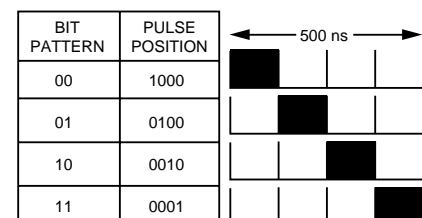

Figure 3.5 4 PPM Modulation.

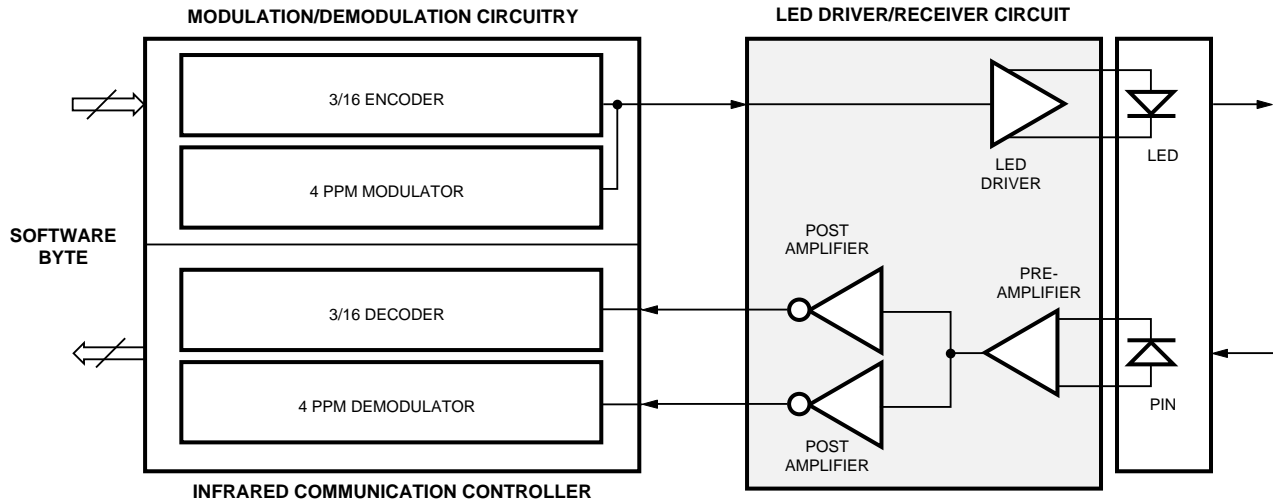

Figure 3.6 IrDA Version 1.1 Physical Layer Block Diagram.

Table 3.1 Standard Power Key Physical Layer Parameters

	Applicable Data Rates	Minimum	Maximum
ACTIVE OUTPUT (TRANSMITTER) SPECIFICATIONS			
Peak Wavelength, μm	All	0.85	0.90
Maximum Intensity In Angular Range, mW/Sr	All	–	500
Minimum Intensity In Angular Range, mW/Sr	115.2 kbps and below	40	–
	Above 115.2 kbps	100	–
Half-Angle, degrees	All	± 15	± 30
Rise Time T_r & Fall Time T_f , 10 - 90% ns	115.2 kbps and below	–	600
	Above 115.2 kbps	–	40
Optical Over Shoot, %	All	–	25
Signaling Rate and Pulse Duration		See IrDA Spec	See IrDA Spec
Edge Jitter, % of nominal bit duration	115.2 kbps and below	–	± 2.3
Jitter Relative to Reference Clock, % of nominal bit duration	0.576 and 1.152 Mbps	–	± 2.9
Edge Jitter, % of nominal chip duration	4.0 Mbps	–	± 4.0
ACTIVE INPUT (RECEIVER) SPECIFICATIONS			
Maximum Irradiance In Angular Range, mW/cm^2	All	–	500
Minimum Irradiance In Angular Range, $\mu\text{W}/\text{cm}^2$	115.2 kbps and below	4.0	–
	Above 115.2 kbps	10.0	–
Half-Angle, degrees	All	± 15	–
Receiver Latency Allowance, ms	All	–	10
LINK INTERFACE SPECIFICATIONS			
Minimum Link Length, m	All	0	0
Maximum Link Length, m	All	1	–
Bit Error Ratio, BER	All	–	10^{-8}
Receiver Latency Allowance, ms	All	–	10

second, third or fourth 125 ns time slot. Thus a demodulator, after phase locking on the incoming bit stream, can determine the data pattern by the location of the pulse within the 500 ns period. The demodulator phase locks with a string “preamble” field. A preamble consists of 16 bits, and is transmitted 16 times.

The block diagram for the Version 1.1 (4 Mbps) Physical Layer (Figure 3.6) looks similar to the Version 1.0 block diagram, except that the UART and the Encode/Decode circuitry are replaced with an I/O device that is designed for 4 Mbps IrDA data communication. This device performs the encoding and decoding of both the 3/16 and the 4 PPM modulation.

Key Physical Layer Parameters

The IrDA physical layer specification defines the requirements for a serial, half-duplex IR link that will communicate with another IrDA device at distances from 0 to 100 cm (standard power device). The key physical layer parameters are shown in Table 3.1.

Note: More information may be obtained from the IrDA Serial Infrared Physical Layer Specification (currently Version 1.3).

Optical Requirements

Figures 3.7 and 3.8 show the IrDA requirements for output intensity and input irradiance vs. angle. For the output (Figure 3.7), the intensity at any point within a cone of half angle 15° with respect to the optical axis, must fall between the minimum and the maximum values. The intensity at any point outside of a cone greater than 30° with respect to the optical axis, must fall below the minimum value.

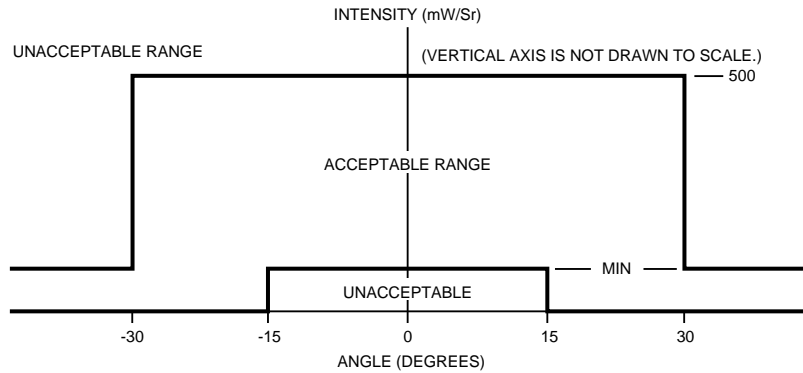

Figure 3.7 Acceptable Optical Output Intensity Range.

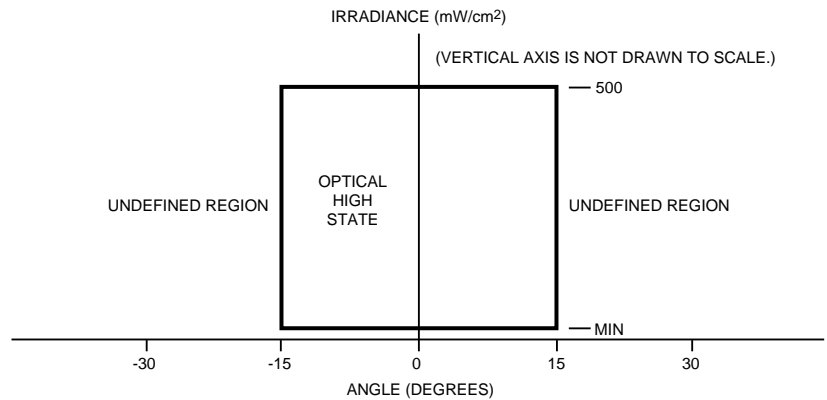

Figure 3.8 Optical High State Range.

For the optical input (Figure 3.8), the receiver must be able to recognize a signal between the minimum irradiance (depending upon data rate, per Table 3.2) and the maximum of 500 mW/cm², at any point within a cone of 15° with respect to the optical axis.

Low Power Option

The low power option specification was added to the IrDA 1.2 physical layer specification to cater to Telecom applications, where low power operation is more important than the link distance. Under the low power option, the minimum link distance when two low power option devices communicate is 0 to 20 cm. However, when a standard power device communicates with a low

power option device, the minimum link distance range is increased to 0 to 30 cm. Note that under version 1.2, the maximum supported data rate is 115 kbps.

Version 1.3 of the IrDA Physical Layer specification extends the low power option to all data rates up to the maximum of 4 Mbps.

Table 3.2 shows the key physical parameters for the low power option.

Table 3.3 gives a quick comparison of physical layer specifications for standard power (IrPHY 1.1), SIR low power option (IrPHY 1.2) and FIR low power option (IrPHY 1.3).

Table 3.2 Key Low Power Option Physical Parameters

	Applicable Data Rates	Min.	Max.
ACTIVE OUTPUT (TRANSMITTER) SPECIFICATIONS			
Intensity in Angular Range, mW/Sr	All	–	72
	115.2 kbps and below	3.6	–
	Above 115.2 kbps	9	–
ACTIVE INPUT (RECEIVER) SPECIFICATIONS			
Irradiance in Angular Range, mW/cm ²	All Speed	–	500
	115.2 kbps and below	0.009	–
	Above 115.2 kbps	0.0225	–
Receiver Latency Allowance, ms	All	–	0.5

Table 3.3 Comparison of key parameters between IrPHY 1.1 and 1.3

	SIR/FIR Std Power (IrPHY 1.1)	FIR Low Power (IrPHY 1.3)	Remarks
Link distance, cm			
Lower limit	0	0	
Upper limit (low power to low power)	–	20	} Range per Telecom
Upper limit (low power to std)	–	30	} SIG use model
Upper limit (std power to std power)	100	–	
Data rate, bps			
Minimum	9.6 K	9.6 K	
Maximum	4 M	4M	
Intensity, mW/Sr			
Minimum (\leq 115 kbps)	40	3.6	IrPHY 1.2/1.3 uses < 10% of std power LED drive current, allows small eye safe devices
Minimum ($>$ 115 kbps)	100	9	
Maximum (all data rates))	500	72	
Irradiance			
Min, μ W/cm ² (\leq 115 kbps)	4	9	IrPHY 1.2/1.3 allows use of less sensitive receiver, hence higher minimum irradiance
Min, μ W/cm ² ($>$ 115 kbps)	10	22.5	
Max, mW/cm ²)	500	500	
Latency, ms	10		Lower latency required to prevent voice clipping

Half Duplex and Latency

The IrDA link is half-duplex, and there is a time delay allowed from the time a link stops transmitting to the time when it must be ready to receive. The IrDA link cannot send and receive at the same time because the transmitter and receiver are not optically isolated, and the transmitted signal can interfere with the incoming signal. When the transmitter is emitting light it may even saturate its own receiver, and disable it from receiving data from another source. The IrDA specifications allow a period of 10 ms (Standard Power Option) after transmitting, for the receiver to regain its full sensitivity. Shorter times may be negotiated when the link starts up. This delay, from the time the transmitter stops sending light pulses to the time the receiver is guaranteed to be ready to receive data, is termed latency. **Latency** is also known as **receiver setup time**.

Ambient Light

There are requirements for ambient light rejection to ensure proper working of the IrDA datalink under a wide range of environmental conditions. The IrDA specification specifies the test methods for measuring the data integrity of the link under electromagnetic fields, sunlight, incandescent lighting and fluorescent lighting. An IrDA receiver must be able to reject up to 10K lux of sunlight, 1K lux of fluorescent light and 1K lux of incandescent light. These values were chosen as typical of what may be encountered under normal use conditions. Please refer to the IrDA Physical Layer Test Specification for test methodologies.

3.5 IrLAP - LINK ACCESS PROTOCOL

The IrLAP protocol specification corresponds to the OSI layer 2 (Data Link Protocol), and is a mandatory layer for IrDA protocols. IrLAP is based on the pre-existing HDLC and SDLC half-duplex protocols, with some modifications to cater to the unique features and requirements of infrared communications. IrLAP provides guidelines for the software which looks for other machines to connect to (sniff), discovers other machines (discover), resolves addressing conflicts, initiates a connection, transfers data and cleanly disconnects. IrLAP specifies the frame and byte structure of IR packets as well as the error detection methodology for IR communications. Figure 3.9 shows the block diagram for the IrDA IrLAP function.

IrLAP defines three different framing schemes corresponding to the three types of data rates (9.6 kbps - 115.2 kbps, 0.576 Mbps and 1.152 Mbps, 4 Mbps). The wrapper types for the three physical layer schemes are:

- Asynchronous (ASYNC) Framing (9.6 kbps - 115.2 kbps)
- Synchronous (SYNC) HDLC Framing (576 kbps and 1.152 Mbps)
- Synchronous 4 PPM Framing (4 Mbps)

Figure 3.10 shows the three different types of frame structures. The IrLAP Payload data includes the address, control field and information data. To implement the IrLAP layer, please refer to the IrDA IrLAP specification.

3.6 IrLMP PROTOCOL

The IrLMP (Link Management Protocol) is a layer that sits above the IrLAP layer. It provides services to both the Transport layer and directly to the application layer. IrLMP consists of two components, LM-IAS (Information Access Service) and LM-MUX (Link Management Multiplexer). LM-IAS maintains a database of IrDA devices discovered as well as providing information on what services the IrDA compliant devices offer. LM-MUX provides services to both the local LM-IAS and also to the transport entities or applications that bind directly to the LM-MUX layer. LM-MUX provides a mechanism for linking multiple devices over IrLAP, as well as sharing control of a single IrLAP connection between a pair of stations.

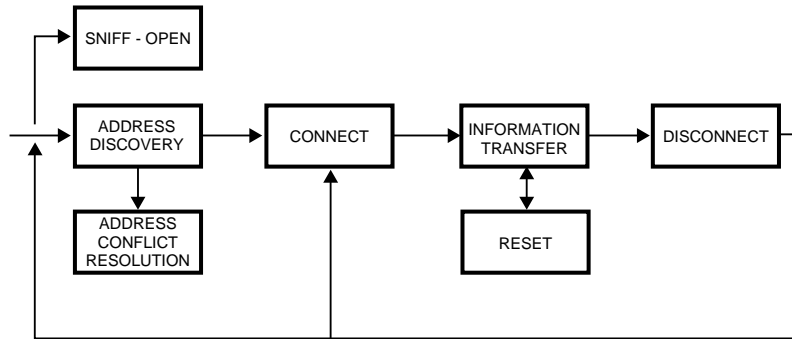
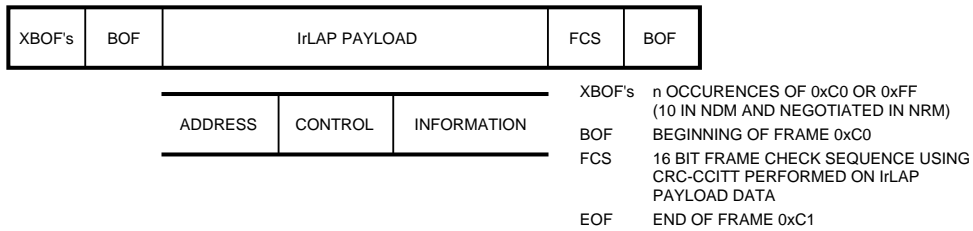
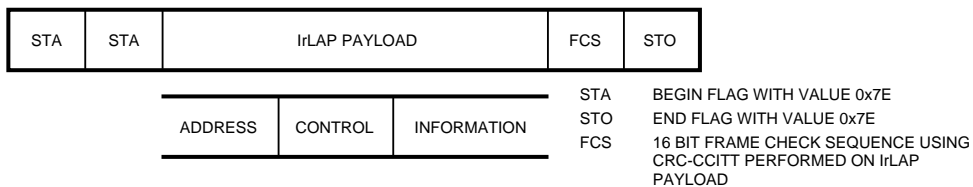

Figure 3.9 IrLAP Block Diagram.

ASYNCHRONOUS WRAPPER (9600 kbps TO 115.2 kbps)



SYNCHRONOUS WRAPPER (576 kbps TO 1.152 Mbps)



4 PPM WRAPPER (4 Mbps)

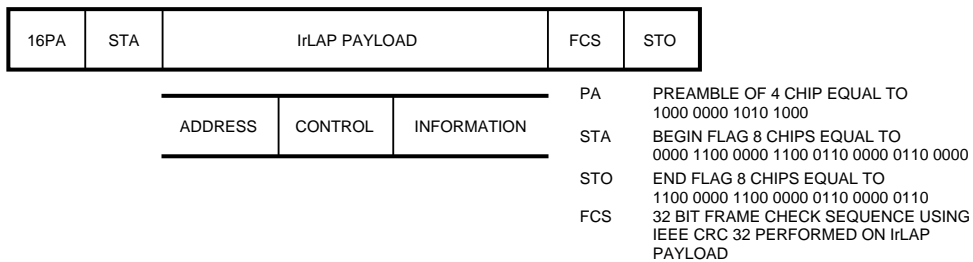

Figure 3.10 IrLAP Frame Structure.

Figure 3.11 shows the Link Management Architecture. IrLMP adds a two-byte header to the IrLAP frame, as shown in Figure 3.12.

3.7 IrCOMM PROTOCOL

IrCOMM (Serial and Parallel port emulation over IR) allows existing communication applications that talk to other devices via serial and

parallel ports to work over IR without any changes in their code.

Normal wired communication methods can send information in both directions simultaneously (i.e., full duplex), as there are multiple wires between them. Under the current specifications, IR is only able to send information

one way at a time (half duplex). Also, after sending data, there is a need to wait for a short period of time (latency or receiver setup time, explained earlier) before it can start receiving. IR uses a short latency of 10 ms to maximize transmission speed. The minimum 10 ms latency is imposed by the hardware. This puts a constraint

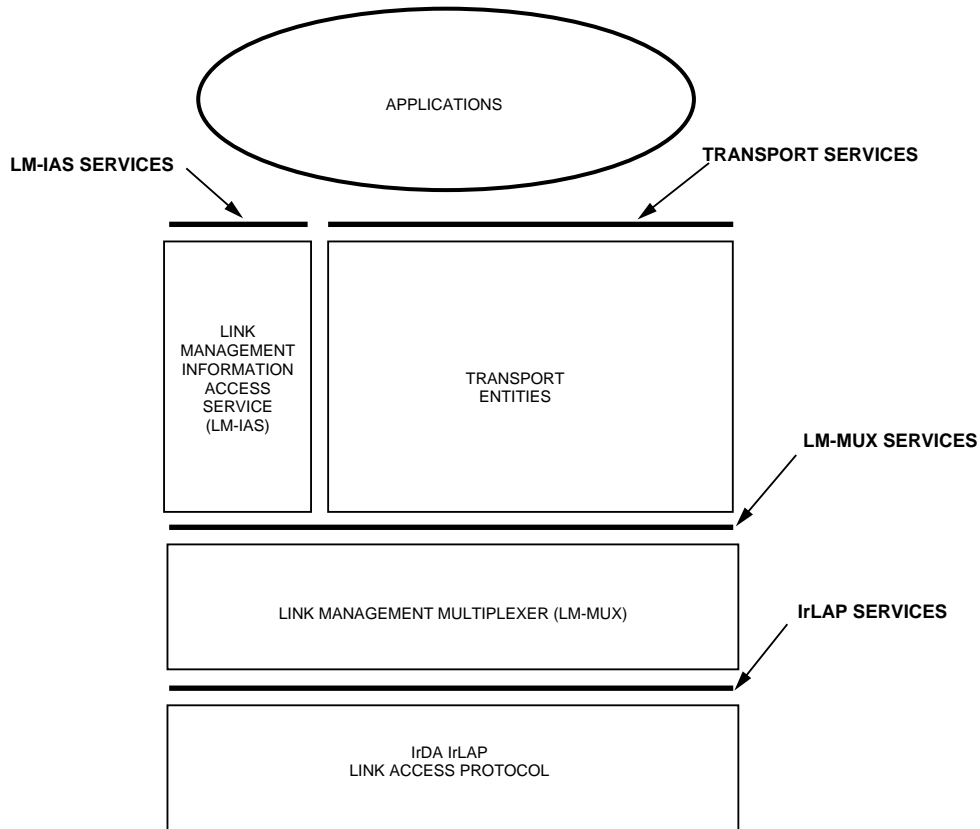

Figure 3.11 IrDA Link Management Architecture.

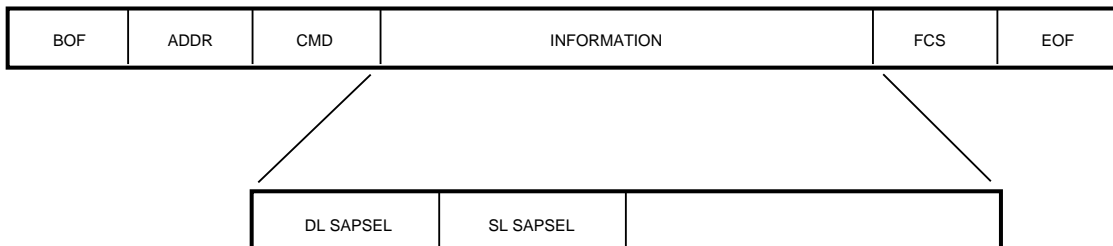

Figure 3.12 IrDA LMP Frame Structure.

on critical timing applications via serial and parallel ports. However, most communication tasks are not time critical and should not present a problem.

IrCOMM provides four service types or classes: 3-Wire raw, 3-Wire, 9 Wire and Centronics. The service type falls into two types, raw and cooked. Three wired raw provides a data channel only, and utilizes the IrLAP flow control, while the cooked type supports a control channel and employs tinyTP flow control. In the cooked mode, the control signals (CTS and RTS for example) are encoded and transmitted serially as commands. The IrCOMM layer in the receiving device decodes the commands and reports them to the next higher layer. Figure 3.13 shows a block diagram of how this is done.

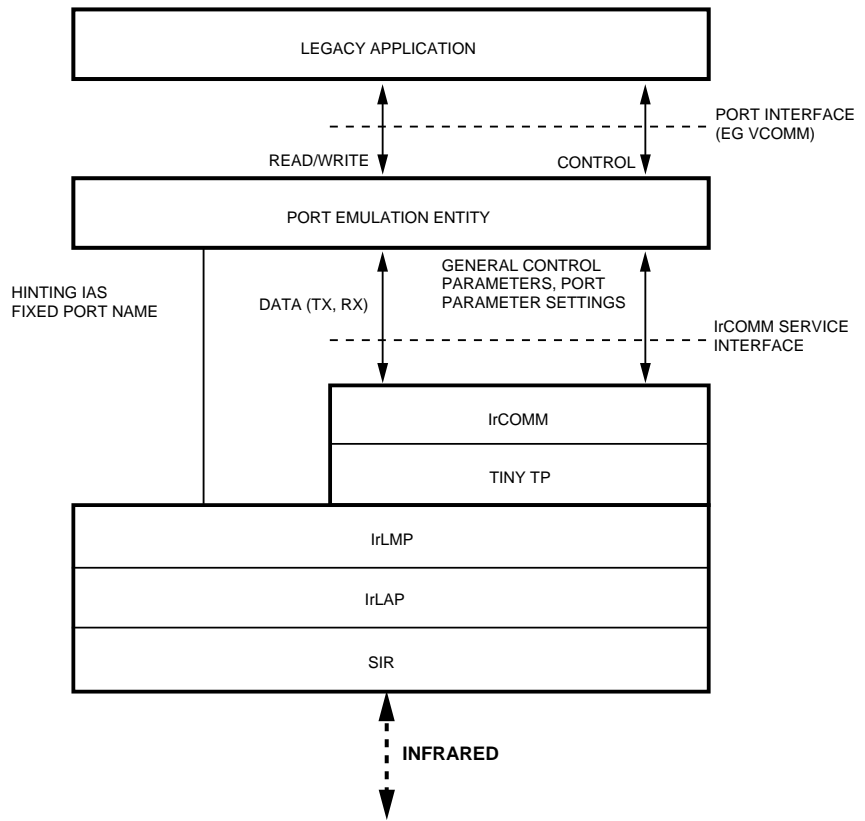

Figure 3.13 IrDA IrCOMM Architecture.

3.8 IrTRANP

The IrTran-P (Infrared Transfer Picture) is a standard jointly defined by Casio, Okaya Systemware, NTT, Sharp, and Sony, specifically targeted for digital still camera picture transfer application. Its goal is to transfer a picture from a digital camera to other equipment over IrDA link and guarantee the same picture quality after the transfer. The standard adds three new layers on top of the existing IrDA protocol stack (as illustrated in Figure 3.14):

- **SCEP** (Simple Command Execute Protocol): a session layer designed to work on the highly reliable transport layer. It establishes a session on top of the IrDA's stack IrCOMM layer to provide connection and com-

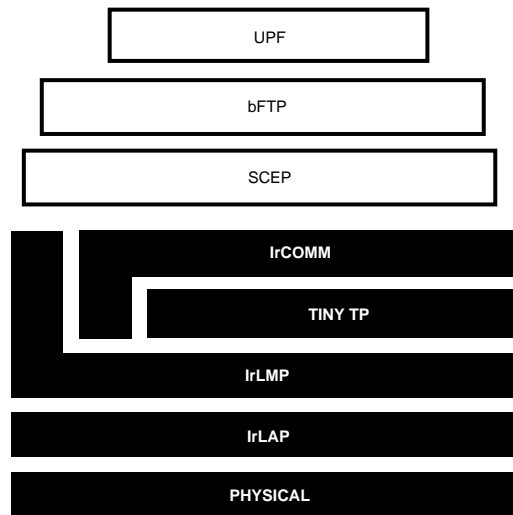

Figure 3.14 IrDA TRANP Architecture.

mand management services. The session will operate at the speed determined by the underlying stack and infrared hardware.

- **bFTP** (Binary File Transfer Protocol): designed to work with SCEP. It provides a mechanism for exchanging binary files by using the following services:
 - F_Put: Transmit a data file to a responder.
 - F_Query: Request the processing ability of the application on the responder.
- **UPF** (Unified Picture Format): standardization of picture data format with base picture size of VGA 640 x 480 pixels.

3.9 IrMC

The **IrMC** (Infrared Mobile Communications) standard, established by the IrMC Working Group, is targeted at mobile communications devices, such as mobile phones, notebook PCs, PDAs, pagers, and even wrist-watches. The core members of the working group are Ericsson, Motorola, Nokia, NTT DoCoMo, and Puma. Phase 1 of the IrMC specifications covers the following use models:

- **Exchange of Objects** between mobile devices by means of the **OBEX** (Object Exchange) protocol. Examples of objects include the Versit vCard, vCal, vMsg and vNote. Very small devices such as pagers and watches can cut down their IrMC code size significantly by implementing the very tiny, connectionless, limited functionality **Ultra** protocol stack.

- **Call Control** commands transmitted between the mobile equipment and terminal equipment (car cradle or PC/PDA).
- **Audio** for real time voice and control service data transmission made possible by the **RTCON** (Real-time Transfer Control) protocol. RTCON is a full duplex protocol that adopts the ITU-T G.726 32 kbps ADPCM as the common voice codec (**compression/decompression**) method. To avoid any noticeable clipping of sound, it requires the use of IrDA transceivers with latency of less than 500 μ s.

support is mandatory, while most others are optional.

To meet the low power consumption requirements of mobile Telecom products, the **Low Power Option** has been added in IrPHY version 1.3. This lighter physical layer defines a much shorter link distance of 20 cm from IrMC to IrMC devices, and 30 cm from an IrMC to a standard power device. The shorter link distance results in up to ten times savings in LED drive current.

The IrMC specification defines various levels of support for the above applications. Some of the

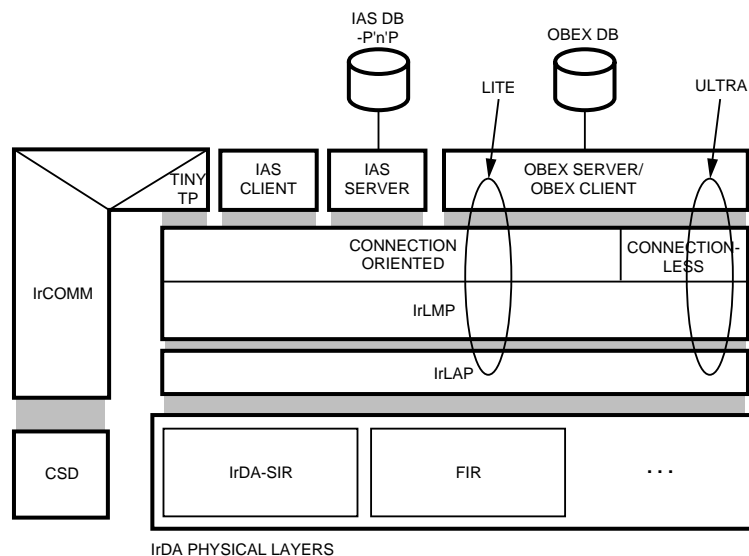

Figure 3.15 IrMC Architecture.

3.10 IrOBEX (IrDA OBJECT EXCHANGE PROTOCOL)

OBEX is an application layer protocol that enables different systems to exchange a wide variety of data and commands in a standardized fashion. OBEX is quite similar to HTTP, in that objects carry information about themselves in the form of headers. As such, it addresses one of the most common applications (file transfer) on either PCs or embedded systems, in that it can take the objects from the host, and beam them over to the receiving device using infrared. As OBEX takes the task out of the applications of dealing with the communication process, it enables easy implementation of an IrDA communication transaction and simplifies the development of communications enabled applications.

OBEX consists of the following components:

- **Object Model:** Provides a way of classifying the objects. The object model contains information about the objects, as well as the objects themselves.
- **Session Model:** The Session protocol takes care of the communication between two devices. It makes use of a binary packet based request/response model.
- **IAS entry:** It defines an IAS entry for default OBEX server, and hint bits for the service.

Figure 3.16 shows where OBEX fits into the overall scheme of the IrDA protocols.

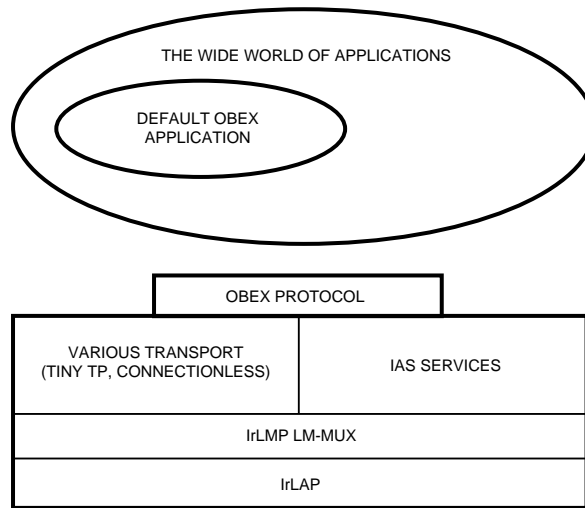

Figure 3.16 IrOBEX Architecture.

3.11 SOFTWARE SUPPORT

The following manufacturers provide application software, drivers and IrDA protocol stacks. The addresses and phone numbers are listed in the Appendix under **Reference List**.

- Microsoft - Operating System
- Linux -Operating System (under development)
- Geoworks
- Extended System
- CounterPoint Systems
- Puma Technology
- Actisys
- Parallax Research
- Okaya SystemWare
- Phoenix
- Open Interface

Microsoft Windows operating systems support the IrDA protocol stack, and provide IR sockets as the application programming interface for companies developing IrDA applications. Currently Microsoft provides IrDA support for the following operating systems: Windows 95, Windows 98, Windows CE, and Windows 2000.

4. IrDA Future Directions

4.1 *Very Fast IR (VFIR)*

Very Fast IR (VFIR) is the high speed extension of IrDA Data 1.1, pushing the cost/performance curve to a new level bringing end users faster throughput without substantial increase in cost. Fully backward compatible with previous data rates, it represents the lowest cost and highest speed cordless technology available today. VFIR addresses the emerging capabilities of, and user demand for, digital cameras, scanners, portable storage devices and infrared LAN access points as well as for notebook and desktop PCs. The IrDA board has approved changes to the physical layer and link access protocol specifications that enable the 16 Mbps extension.

The new standard is based on a joint proposal from Hewlett-Packard Company, IBM Corporation, and Sharp Corporation and has the following features.

- Data Rate - 16 Mbps
- Fully backward compatible with previous implementations of IrDA
- Link Distance (same as previous versions of IrDA) - 1 meter minimum and $\pm 15^\circ$ field of view.
- Encoding - HHH(1, 13) with scrambling that optimizes encoding efficiency, duty cycle and duty cycle variation
- Reduced receiver latency of 100 μ s for higher throughput.
- Minor changes in the IrDA IrLAP protocol, such as defining a new data rate bit for 16 Mbps and increased window size from 7 to 127 (optional).

5. Agilent Products

5.1 INTRODUCTION

Having selected an architecture, the IrDA system designer can now select the proper components and develop the circuit diagram.

Agilent manufactures a broad selection of products that may be used to implement a variety of IrDA designs. Please refer to the Agilent Infrared Components Selection Guide for an overview of these products. This section will describe the characteristics of these various components. Please see the Data Sheets or Product Catalog for specific parametric information.

5.2 INTEGRATED TRANSCIVER MODULES

Agilent offers a wide range of SIR, MIR and FIR transceivers. VFIR transceivers are currently in development. Agilent transceivers are designed to offer fully IrDA compliant receive and transmit functions for the system. The transmitter converts the modulated pulses received from the I/O chip or endec into IR light pulses. The receiver detects IR light pulses and converts them to TTL or CMOS level compatible electrical pulses.

The integrated design of Agilent transceivers enables ease of implementation and compliance to all IrDA physical layer specifications. It includes the optics, LED with buffered LED driver, and PIN photodiode and receiver circuits in one package. The design of the transmitter guarantees the intensity and viewing angles required by IrDA, while the receiver circuitry enables data transfer at guaranteed link distances from 0 cm (nose to nose) to at least 1 meter, even in the presence of ambient electrical and optical noise.

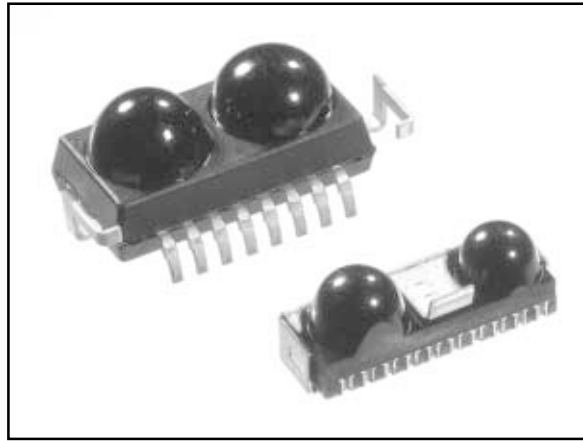

Figure 5.1 Agilent Integrated Transceiver Modules.

All Agilent transceivers are guaranteed to meet all IrDA specifications over the operating temperature, supply voltage and life of the part. All electrical specifications are also guaranteed over temperature, voltage and lifetime. Supply voltage range is over the full range from 2.7 V and 5.5 V.

Over the years Agilent's transceiver offering has evolved to incorporate more and more features enabling ease of use and fulfilling market needs for miniature packaging, low power consumption, improved optical and electrical performance required of higher data rates, and added sophistication. Following are some of the features that have been added:

Constant current: The current generated from an external voltage source using an external resistor usually drives the LED portion of the transceiver. However, this is vulnerable to voltage fluctuations. An alternative would be to drive the LED internally using a constant current source. Besides being resistant to voltage

fluctuations, this has the added advantage of reduced component count by doing away with the external resistor. This feature is found in the HSDL-3201 and the HSDL-3202.

I/O V_{CC} interface: Low power consumption and miniaturization usually lead to development of low-voltage applications. Handheld devices are currently heading toward voltages as low as 1.8 V. This implies that transceivers should be capable of interfacing with low logic level ASICs. The I/O V_{CC} interface enables the transceiver to interface with such low voltage logic levels. This feature is currently found in the HSDL-3202 and is expected to be in all next generation transceivers that fit such a low voltage application scenario. See the section on I/O V_{CC} interface in *Architectural Options*.

Power management: To operate over the entire link distance specified by IrDA, the IrDA physical layer specification requires LED intensity ranging from 40 mW/Sr to a maximum of 500 mW/Sr. A long link distance

(1 m) would require a high intensity, but the same intensity at shorter link distances would be overkill. Reducing the intensity down to the required level will have the LED operating at an optimal level and will also result in lower power consumption. User adjustable optical power level adjustment is provided via software or hardware controllable pins. This feature is found in the HSDL-2300. See the section on Interfacing for adaptive power management under *Architectural Options*.

Serial Interface for Transceiver Control (STC):

Adding new features to transceivers usually translates to increased pin count for the user to access and control these features. To overcome this, IrDA specified the Serial Interface for Transceiver Control. STC is used to control and program the features of the transceiver, which include data rate control, input/output control and optical power management. This feature is found in the HSDL-3210 and will be available in Agilent's next generation of transceivers. See the section on STC interface in *Architectural Options*.

Transmitter

The transmitter uses a high speed, high efficiency TS AlGaAs LED, along with a high speed drive circuit to produce high power IR pulses with minimal pulse width distortion. The transmitter features a buffered input to reduce input current so it can be driven directly by CMOS logic. The efficiency of the LED and the optical design of the package guarantee IrDA specified minimum and maximum light intensity. The speed of the LED and drive cir-

cuitry minimizes the rise and fall times of the LED signal edges, improving the detection capability of the corresponding IR receiver. The transmitted radiant intensity allows for an additional guard band to accommodate for losses due to the cosmetic window and thus guarantees the required minimum and maximum intensity levels as specified in the physical layer specification of the IrDA, even outside the system. The transmitter uses fewer external components. These include power supply filter capacitors and LED current limiting resistor. The resistor is not required when a constant current source for LED drive is used such as in the case of HSDL-3201/3202 options. The choice of components is further discussed in the section *Layouts and Schematics* and can also be found in the respective data sheets.

Receiver

Unlike the transmitter portion, the receiver must handle a large dynamic range, multiple data rates and line codes, making it more difficult to design. The receiver digitizes the incoming signal by comparing it to a threshold value. The dynamic range required by IrDA of the receiver, for a one meter link are $4 \mu\text{W}/\text{cm}^2$ to $500 \text{ mW}/\text{cm}^2$ for 2.4 to 115.2 kbps and $10 \mu\text{W}/\text{cm}^2$ to $500 \text{ mW}/\text{cm}^2$ for 0.576 to 4 Mbps. This implies that for higher data rates the receiver threshold should dynamically adjust according to the incoming signal amplitude. Since noise levels are higher at higher data rates, a fixed threshold level would miss bits or give rise to extra bits in the presence of noise. AGC (automatic gain control) circuitry can be used in an IR receiver to obtain a wide dynamic range. However,

this does not guarantee compliance to IrDA specifications. Moreover, AGC circuitry has been shown to have high bit error rate (BER) at large signal levels (short link distances). Alternatively, an adaptive threshold circuit can be used which quickly adapts to an incoming signal and sets the threshold for the quantizer. The adaptive threshold circuit in combination with a squelch circuit makes the receiver robust and immune to spurious signals and provides a wider dynamic range of operation that is required of higher data rates.

Power Supply and EMI Noise

An IR transceiver implementation requires special attention to EMI and power supply noise. The analog functions (IR detector and pre-amplifier) are very sensitive, and thus require more attention to EMI and power supply noise than typical digital integrated circuits. Noise immunity is the maximum amount of noise that the receiver can sense before exceeding a 10^{-8} bit error rate. Noise levels above the noise immunity will effectively reduce the receiver sensitivity and therefore the IR link distance. All IR transceiver solutions require improved ground plane design and capacitive decoupling over standard practices for digital integrated circuits. See the section on *Board Layout Guidelines* for low noise design techniques.

Ambient Light

The IrDA Physical Layer Specifications require a receiver to operate correctly in the presence of sunlight, incandescent light and fluorescent light. Agilent's IR transceiver modules are guaranteed by design to work under all of the above-

specified conditions. They incorporate a combination of optical and signal processing techniques to achieve this performance. The package mold compound is tinted with dye to filter out visible wavelengths. The lens of the detector is designed to be sensitive to light only within the IrDA viewing angle and exclude light from outside of that angle. The first stage amplifier of the receiver contains daylight cancellation circuitry to eliminate the ambient light portion of incoming signals, and the amplifier is bandwidth limited to reject signals out of the IrDA band. Using these techniques, Agilent ensures robust performance under all IrDA specified ambient light conditions.

5.3 Endecs (Encoders/Decoders)

The HSDL-7000 and HSDL-7001 are endec chips that perform the IrDA 3/16 encode/decode function for data rates up to 115.2 kbps, as described in the section on IrDA physical layer. These devices function as the interface between a standard UART and the IR transceiver.

HSDL-7000

The HSDL-7000 performs the IrDA 3/16 encoding and decoding of the pulses from and to the IR transceiver, as specified by IrDA. It is the interface chip between the IR transceiver and a UART. The endec requires a BAUDOUT signal, which is 16 times the selected baud rate. This is either supplied by the standard UART or by some external means. The HSDL-7000 is packaged in an 8 pin SOIC package. The HSDL-7000 interfaces directly to the HSDL-1001, with no external components.

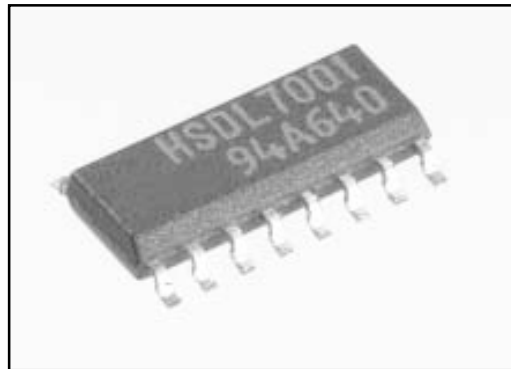

Figure 5.2 Agilent Endec (Encoders/Decoder).

HSDL-7001

Like the HSDL-7000, the HSDL-7001 performs the IrDA 3/16 encoding and decoding of the pulses from and to the IR transceiver. The HSDL-7001 is designed with an internal programmable oscillator for applications where the 16x clock from the serial data source may not be available. This oscillator requires only an external crystal, and uses three data inputs to program the clock. These inputs may be signals such as RTS and DTR from the serial port which would otherwise be unused. If a BAUDOUT signal is available, it may be used instead of the internally generated clock. For transmission, this endec adds the versatility of a 1.6 μ s pulse operation. This allows baud rates lower than 115.2 kbps to use 1.6 μ s pulses for lower power consumption. The HSDL-7001 operates on a supply voltage range from 2.7 V to 5.5 V, and is pack-

aged in a 16 pin SOIC package. The HSDL-7001 interfaces directly to the HSDL-1001, with no external components.

Endec Netlists

For system designers who prefer to embed IrDA communications with an ASIC, Agilent will provide the netlist for the HSDL-7000 at no charge. The HSDL-7000 is about 200 gates logic and the HSDL-7001 is about 1000 gates. This may be useful for system designers who do not require the functionality of a full I/O chip and who do not wish to use a discrete UART. With the IR modulation/demodulation function incorporated into the system ASIC, it can connect directly to the IR transceiver module. Please refer to the application note 1119, "IrDA Physical Layer Implementation for Agilent's Infrared Products", for further information.

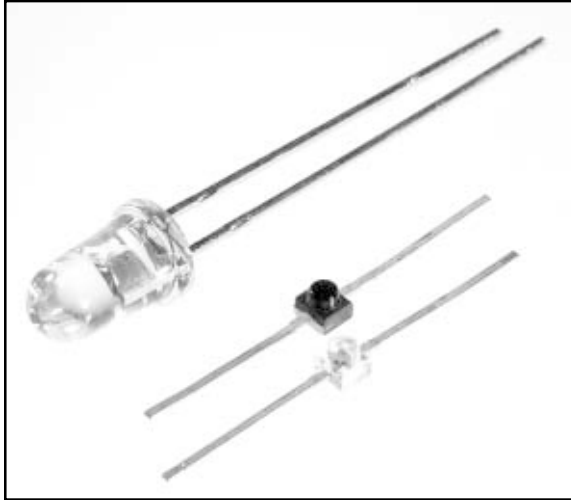

Figure 5.3 Agilent Discrete Emitters and Detectors.

5.4 DISCRETE EMITTERS AND DETECTORS

Agilent makes a number of discrete IR emitters and detectors for supplementing an IrDA link or for proprietary applications. In many cases, it may be desirable for a designer to utilize the basic IrDA framework but make minor modifications for a particular requirement. For example, a particular application may require data transfer over distances greater than 1 meter, or size and power constraints may dictate a low power, short distance, sub-miniature solution.

For long distance applications, Agilent manufactures IR emitters in a variety of package styles. These emitters may be used to supplement the IR output of the transceiver modules by connecting the emitters in series, or by using the HSDL-1001's capability

to drive an external emitter. For details on extended distance applications, please see the section on *Extended Transmission Distance - Beyond IrDA*.

For lower power, space constrained applications where a full meter distance is not required, Agilent manufactures IR emitters and detectors in subminiature packages. These products enable development of "IrDA compatible" short distance links. A number of support circuits are available, or the analog functions can be incorporated into the system's ASIC.

A complete description of these products is available from the Agilent website.

6. Architectural Options

Introduction

This section presents a number of system architectures and typical products for which they are appropriate. Choosing an architecture is where an IrDA design begins.

6.1 TYPICAL ARCHITECTURES

Infrared transceivers have gained widespread acceptance and are being used in a wide variety of applications. The application platforms can be broadly classified into personal computers, mobile phones, handheld (e.g. PDAs) and consumer electronics (e.g. MP3 players). Figures 6.1 - 6.4 illustrate how an IR port fits into these different platforms.

As mentioned before, ver 1.0 IrDA architecture was intended to work with a serial port on a conventional UART. To achieve this, a number of design approaches are possible, but will vary slightly based on where the serial data comes from and where the encoding is done. A number of vendors now offer I/O chips with the IrDA encoding and decoding built in.

Typical architectures will usually fall into one of the categories de-

scribed below. The UART with endec (Figure 6.9) architecture described below is similar to the block diagram (Figure 3.3) described in section 3 on IrDA standards, while the easiest to implement in a system are the

“Super I/O” and 4 Mb I/O architectures (Figures 6.5 and 6.6). For specific device recommendations, please refer to the application note, “IrDA Physical Layer implementation for Agilent’s Infrared Products”.

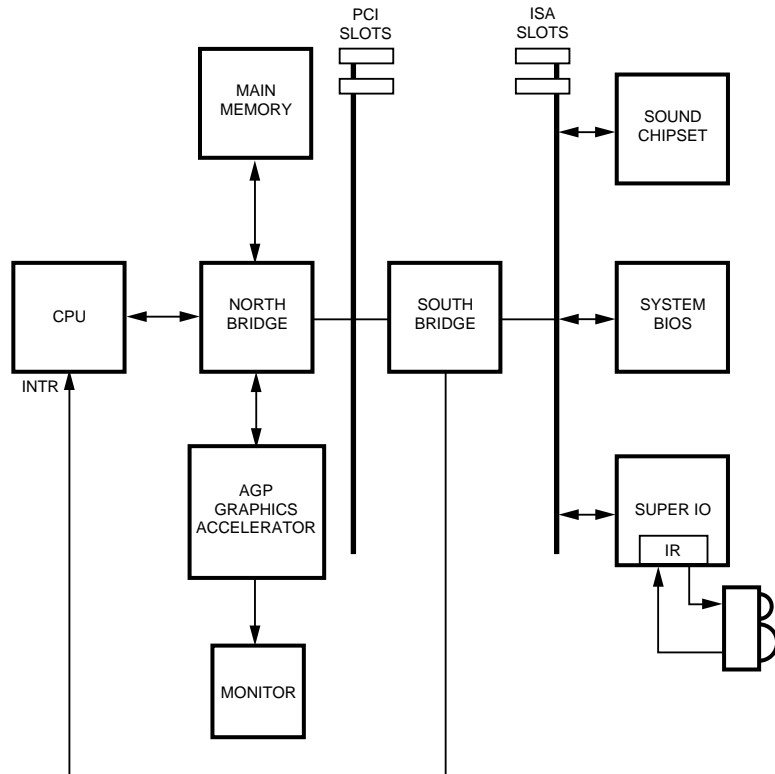

Figure 6.1 PC Architecture.

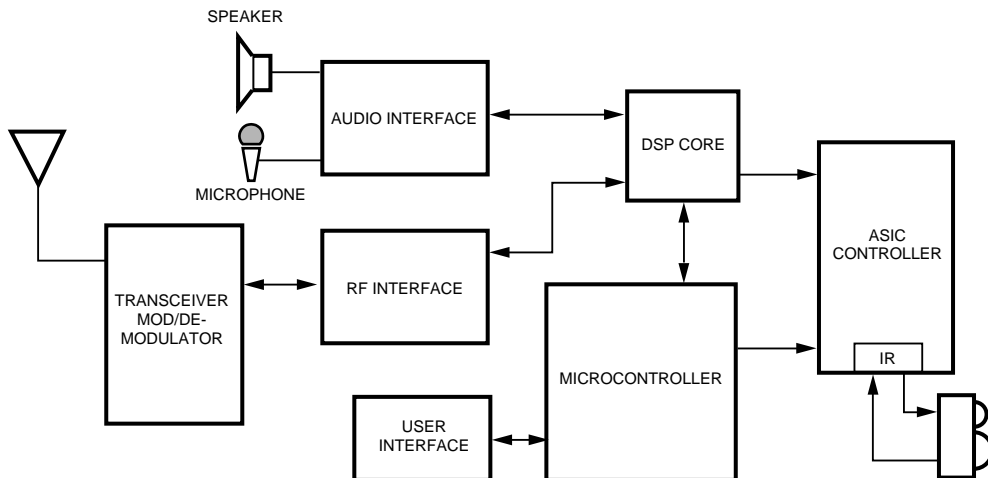

Figure 6.2 Mobile Phone Architecture.

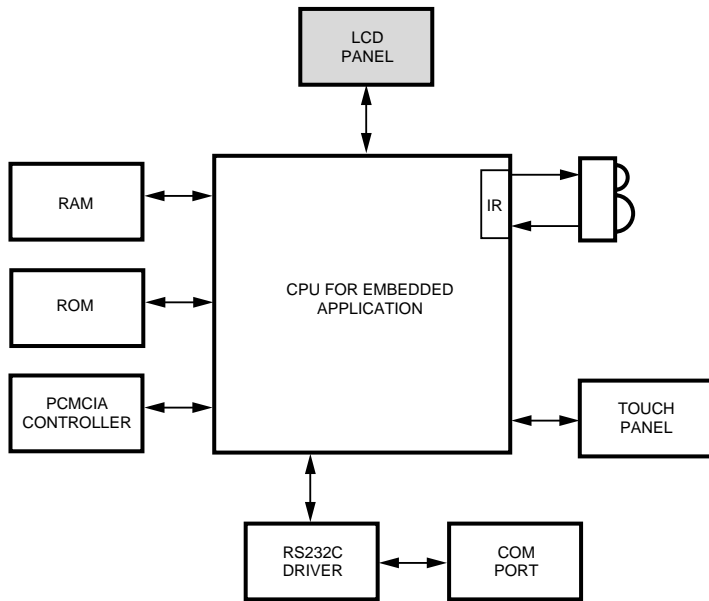

Figure 6.3 PDA Architecture (handheld platform).

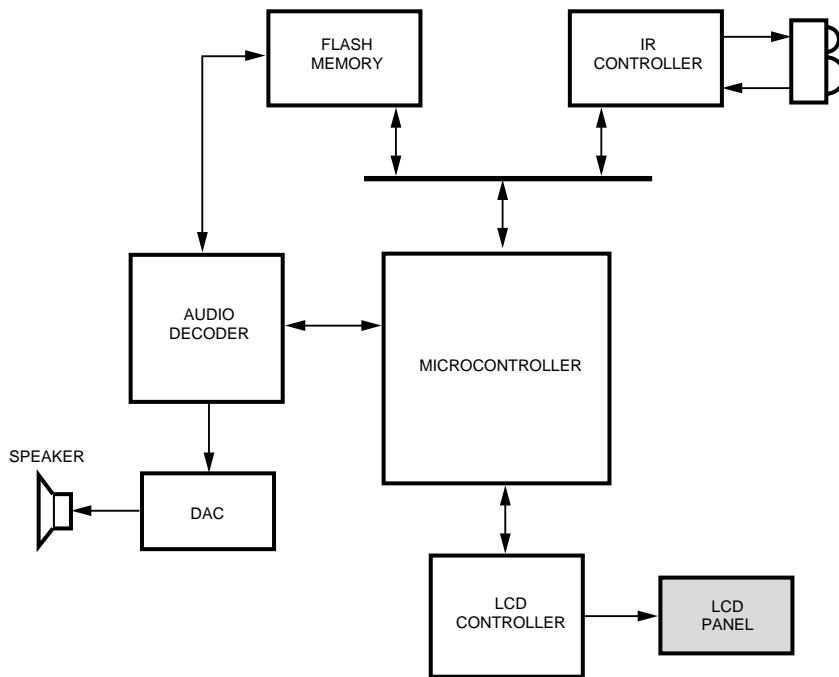

Figure 6.4 MP3 Architecture.

6.2 2.4 kbps TO 115 kbps SUPER I/O

Typical Applications:

Notebook and Desktop PCs

Most PC systems, which typically have a broad range of I/O requirements, can utilize a “Super I/O” chip. In addition to a UART with IrDA encoding and decoding built in, these chips are also able to control the floppy disk drive, hard disk drive, parallel port, keyboard, modem and more.

The serial IR output and input of these Super I/O chips connect directly to the input and output of Agilent’s 115.2 kbps IR transceivers, with no support logic required. For any I/O chip, the configuration register bits must be set so that the I/O chip is set to operate in the proper modes. The settings should be half-duplex, IrDA, SIR, transmit active high and receive active low, UART2 is usually enabled by the bit settings.

Some I/O chips require that the transmit signal be AC coupled to the transceiver module to prevent setting the output in a DC “on” state at power-up. Please refer to the Application Note, “IrDA Physical Layer Implementation for Agilent’s Infrared Products” for details.

Various semiconductor manufacturers including National Semiconductor and Standard Microsystems Corporation (SMC)



HSDL-1001

Figure 6.5 Super I/O Interface (2.4 kbps to 115.2 kbps)

make these Super I/O chips. Please refer to Application Note, "IrDA Physical Layer Implementation for Agilent's Infrared Products" for specific device recommendations.

6.3 2.4 kbps TO 4 Mbps

Typical Applications: Notebooks, Printers or others with ISA or PCI Bus

Since a 115.2 kbps link, as defined by version 1.0 of the IrDA physical layer specification, was designed to work with a conventional UART, it was limited to the maximum data rate supported by the UART, which is 115.2 kbps. The version 1.1 specification extends the data rate to 4 Mbps. This makes it necessary to have an I/O interface different from a conventional UART, and also requires a different modulation scheme.

The block diagram for a 4 Mbps Physical Layer looks similar to Figure 6.6, except that the UART and the encode/decode circuitry are replaced with an I/O device that is designed for 4 Mbps IrDA data communication. Since all IrDA links are required to start up at 9.6 kbps (3/16 modulation), this device does the encoding and decoding for the 115.2 kbps (3/16 modulation) channel as well as the 4 Mbps (4PPM modulation) channel. A number of I/O chips that connect to the ISA bus as well as the PCI bus are available. Please refer to the Application Note, "IrDA Physical Layer Implementation for Agilent's Infrared Products" for a listing of I/O de-

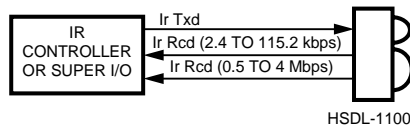

Figure 6.6 2.4 kbps to 4 Mbps

VICES and recommendations for interfacing with them.

Note: All of the following architectures operate up to a maximum data rate of 115.2 kbps.

6.4 16550-type UART, MICROCONTROLLER OR EMBEDDED I/O WITH 16x CLOCK

Typical Applications: PDAs, Industrial Controllers, and Analytical Instruments

Many electronic devices such as PDAs, Industrial controllers and analytical instruments may use a 16550 or similar UART for the I/O interfaces, or have the UART embedded into an ASIC. As seen in Figure 6.7, the UART's TXD output is NRZ (non-return to zero) signal that is 100% duty cycle (full bit width). This signal must be

modulated before transmission, and demodulated (stretched) when received.

A discrete encoder/decoder (endec) chip, such as the HSDL-7000, is used to modulate the data. Figure 6.7 shows how the HSDL-7000 has an IrTXD output that is 3/16 of the bit period (3 of 16 clock cycles). The 16x clock is typically available as a UART output, and is usually called baudout.

In Figure 6.8, the received pulse (IrRXD) is stretched by the endec to the width of 16 clock pulses, or the original bit period. The clocks at both ends of the link do not need to be synchronized, but do need to be at the same frequency, as determined at link startup.

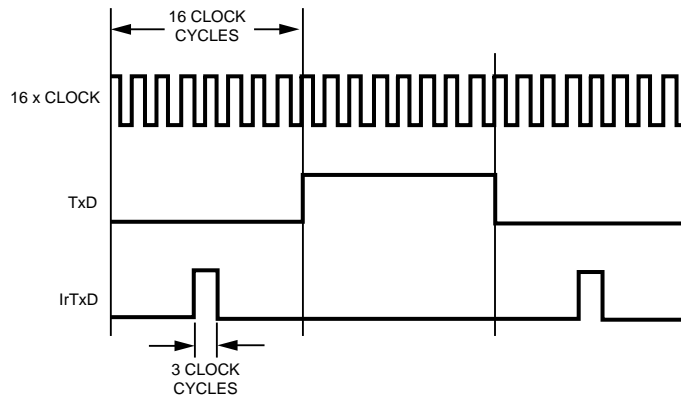

Figure 6.7 IR Transmit.

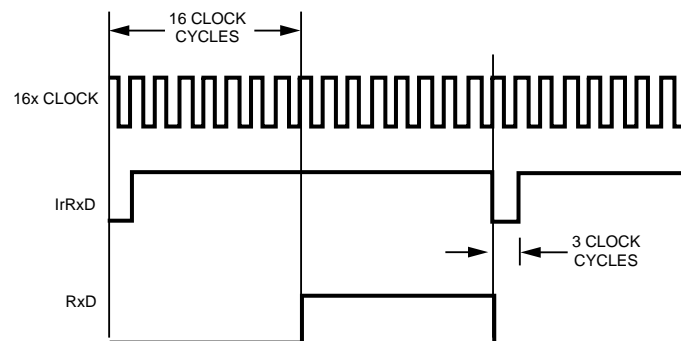

Figure 6.8 IR Receive.

6.5 UART, MICROCONTROLLER OR EMBEDDED I/O WITHOUT CLOCK

For system designers who prefer to embed IrDA communications in an ASIC, Agilent will provide the IrDA ver 1.0 endec netlists at no charge. This may be useful for system designers who do not require the functionality of a full super I/O chip, and who do not wish to use a discrete UART. With the IR encode/decode function incorporated into the system ASIC, it can then interface directly with the IR transceiver module. Please refer to the application note, "IrDA physical layer implementation for Agilent's Infrared Products".

Note that the IrDA transceivers are designed specifically for modulated data and will not work in NRZ mode. This is due to the fact that the receiver generates an output pulse (RXD) for each incoming IR pulse. The width of the receiver's RXD output pulse is typically not more than 20 μ s, regardless of the width of the IR input pulse. Thus, a continuous string of "1" bits (in NRZ coding) would look like one single incoming bit, and thus would be erroneously translated to just one pulse at the transceiver's output.

Typical Applications: Custom I/O, Portables, and some Microcontrollers

In some systems, a 16x clock for the endec may not be provided by the system and must be generated. As mentioned earlier, IrDA only requires that a link operate at 9.6 kbps. Thus, a clock for a system that runs only at 9.6 kbps need only provide a fixed frequency clock that runs at 16 times 9600, or 153600 Hz. A system that needs to go faster will need a means of changing the data rate and thus programming the clock. This can be done with either the HSDL-7000 and some external circuitry, or with the HSDL-7001

which has an internal programmable oscillator. In either case, the oscillator is typically programmed with RS232 lines that are not used in an IR link, such as RTS and DTR, or others. Such a system would need software drivers to correctly configure the programming signals to convey baud rate information. Please see the references for suppliers of software drivers.

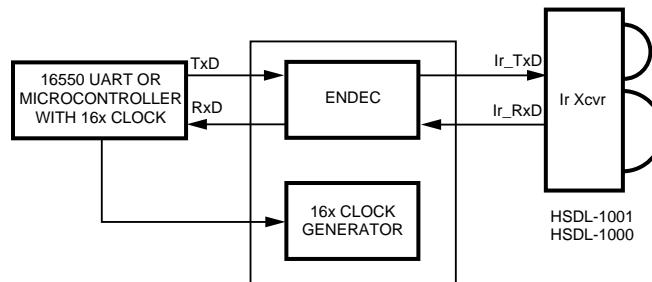

Figure 6.10 UART, Microcontroller or Embedded I/O without Clock.

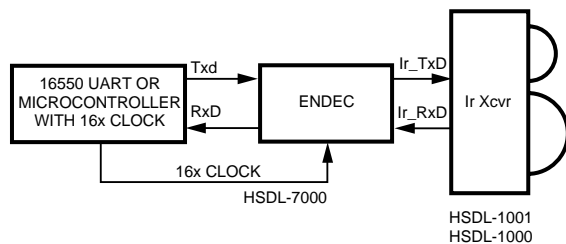

Figure 6.9 16550 UART or Microcontroller with 16x Clock.

6.6 INTERFACE TO RS-232 PORT

Typical Application: Add IR functionality to RS232 port

Some IR ports may be designed to work with existing products and communicate through the RS232 port, or designed as external IR adapters. In these cases, the architecture is similar to Figure 6.10, where the data needs to be encoded but no clock is available. As above, the clock will need to be generated in the IR adapter, and to go faster than 9.6 kbps, will require a programmable clock. Also, the voltage levels need to be shifted to RS232 levels back to logic levels using one of the commercially available RS232 interface circuits. Finally, sufficient power must be provided so that the peak pulsed LED forward current is available to the transmitter while sending data. The average current will be I_f (from data sheet) $\cdot 3/16 \cdot$ (percentage of 0s in the data stream). At data rates slower than 115.2 kbps, the pulse width may be fixed at 1.6 μ s instead of 3/16 of the data rate to reduce average current.

6.7 I/O V_{CC} INTERFACING WITH LOW VOLTAGE ASICs

As designs for handheld devices become more power efficient and to move toward low voltage ASICs, it becomes essential to provide a low voltage I/O interface. ASICs can operate at voltages as low as 1.8 V, and interfacing with current transceivers can be through the use of level shifters. Alternatively, transceivers with a low voltage interfacing capability, such as the HSDL-3202, can be used. The following circuit diagram (Figure 6.12) shows a typical interfacing technique of the HSDL-3202 with a low voltage ASIC logic controller. The ASIC is assumed to be running at a supply voltage as low as 1.8 V. It should

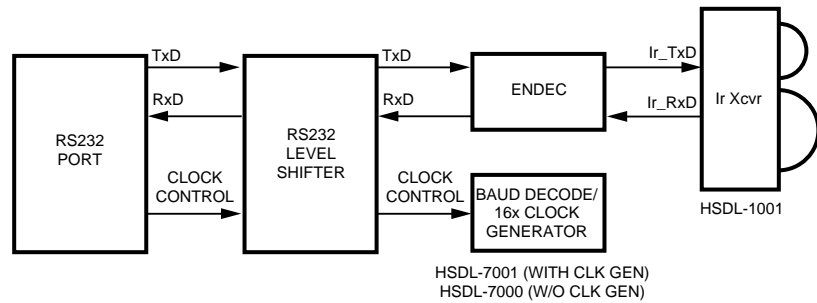

Figure 6.11 RS232 Adapter.

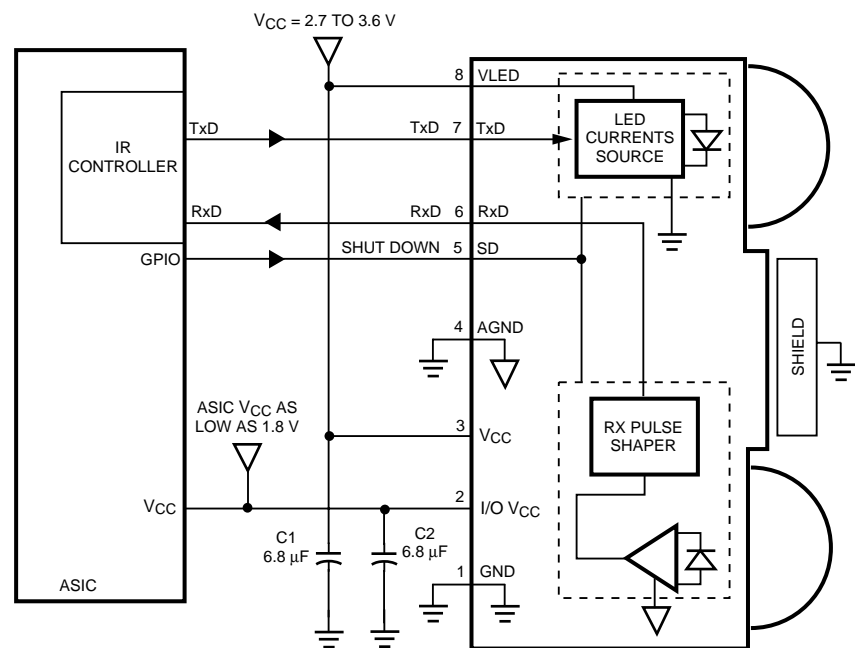

Figure 6.12 I/O V_{CC} Interfacing.

be noted that the ASIC is assumed to have a built-in IR controller core. The above interfacing is required since the IR controller is running at a 1.8 V supply, the same as the ASIC. Essentially, I/O V_{CC} enables interfacing with low input-output logic circuits. If an external IR controller were to be used, at a supply voltage the same as that of the transceiver, the I/O V_{CC} interface is not required. I/O V_{CC} can be shorted to V_{CC} of the transceiver.

6.8 INTERFACING FOR ADAPTIVE POWER MANAGEMENT

Agilent transceivers provide a user-controllable power management option in the form of two pins, which can be controlled via a micro-controller. This feature is currently available in HSDL-2300, HSDL-3600 and HSDL-3610 options. At close link distances it is not necessary to transmit at full power. It would be more economical to transmit at the required power levels. This power conserving mechanism is made available by selecting from the

Table 6.1

Mode 0	Mode 1	Tx function
1	0	Shutdown
0	0	Full distance power
0	1	2/3 distance power
1	1	1/3 distance power

three different power level settings in the transceiver by setting the two mode select pins via software control in a microcontroller. The mode select table is shown in Table 6.1.

The implementation can either be static or dynamic. In the static case, the user is required to select and set the transmit power level required according to the table given above. In the dynamic case, power mode control is initiated and managed by the primary device. For example, in the case of a PDA (primary) communicating with the printer (secondary), the PDA would control the power mode. A sample session is mentioned below. This is just one of the many possible ways of implementing adjustable power. The user is assumed to be using the JetBeam protocol stack.

1. On PDA power on, the JetBeam stack is initialized for adaptive power mode.
2. The PDA's startup code initializes a "threshold" value, which is the number of bytes sent before the power mode is cycled up or down. This in essence sets the frequency at which it adapts its power level.
3. The JetBeam stack programs the mode pins of the transceiver to the default high state.

4. The PDA then establishes an IrLAP connection.
5. Data is transmitted across and the algorithm tracks the number of bytes transmitted.
6. Once the "threshold" number of data has been transmitted successfully, the power level is stepped down one notch. The "threshold" counter is reset and steps 5 and 6 are repeated until the power mode reaches the lowest level.
7. In the event that an acknowledgement is not received by the PDA from the

printer, it is quite possible that the packet sent out was not received by the printer or was corrupted. In this case, the PDA receives a timeout. The algorithm responds by stepping up the power level and re-transmitting the previous packet. This process is repeated until the communication session is re-established.

The hardware interfacing using a Motorola Dragonball MC68328 and HSDL 3600 as an example is shown in Figure 6.13.

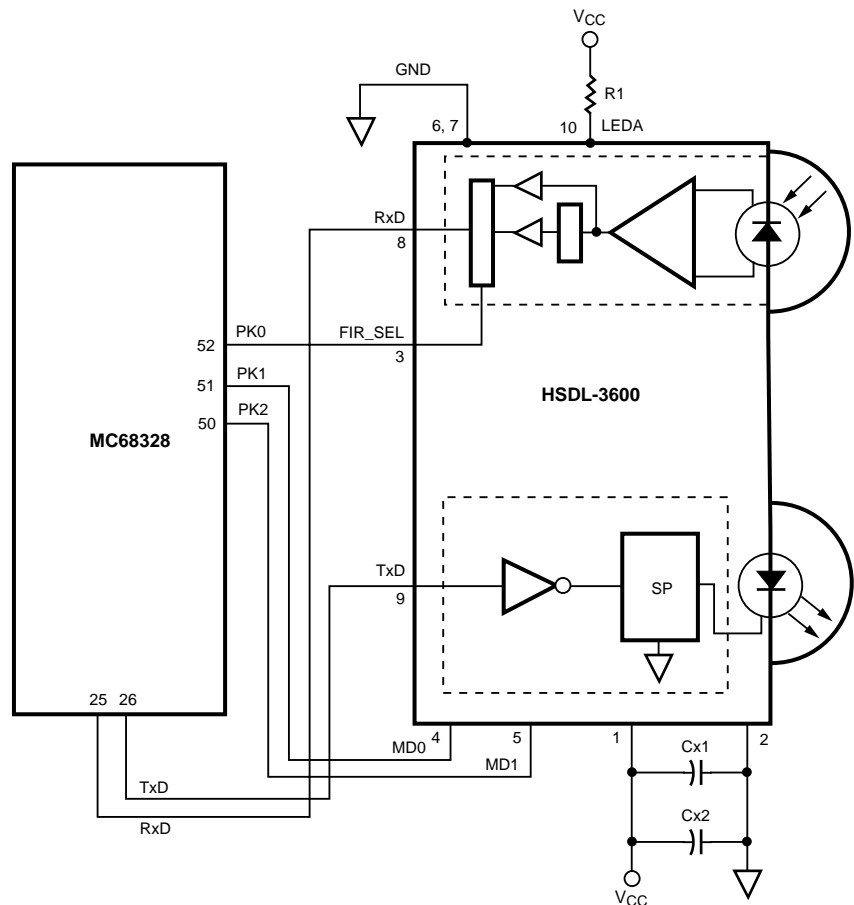

Figure 6.13 Power Management Interface.

6.9 SERIAL TRANSCEIVER CONTROL

Serial Transceiver Control (STC) is the latest way to interface to the transceiver. This 3-wire bus allows connection of up to 6 individually addressable devices and offers a common electrical interface. Registers on board the transceiver store operating modes and states, eliminating the need for additional status/mode pins – this electrical interface can be standardized across different vendors and transceivers. This allows use of a generic framer, and brings plug and play down to the transceiver level.

The first Agilent offering with STC is the HSDL-3210.

STC “transactions” are sent and data received on data lines multiplexed with the normal transmit and receive lines, while a clock line determines whether the transceiver operates as a normal

transceiver or in STC mode. The transactions may be WRITE only (change operating mode) or READ (obtain operating mode or condition). Typical operating modes are stored in the main control registers, and include speed, power levels, receiver output enable, and LED enable. There are extended index registers, which are optional, except for two, ManufacturerID and DeviceID.

Figure 6.14 shows the multiplexing of SCLK write and read lines with the normal IR transmit and receive lines. Figure 6.15 shows two transceivers connected to one IR controller.

6.10 COMMAND FORMAT

The command format consists of a mandatory command phase and an optional response phase. The controller always is the master, and initiates commands. The

transceiver is the slave and responds to commands/read requests. The command phase is a single byte, with a bit indicating write/read, a 3-bit address field and a 4-bit command index field. The response from the transceiver is carried in the 2nd byte. There are 3 byte commands which use the extended index registers. The command consists of the first 2 bytes while the response is carried on the 3rd byte. The commands/responses are sent in little endian form, i.e., the least significant bit of the first byte is sent first, and the most significant bit of the 2nd byte (or 3rd byte in the case of a 3 byte transaction) is sent last.

Figure 6.16 shows the command format.

The address field is defined in the specification, and can be used to

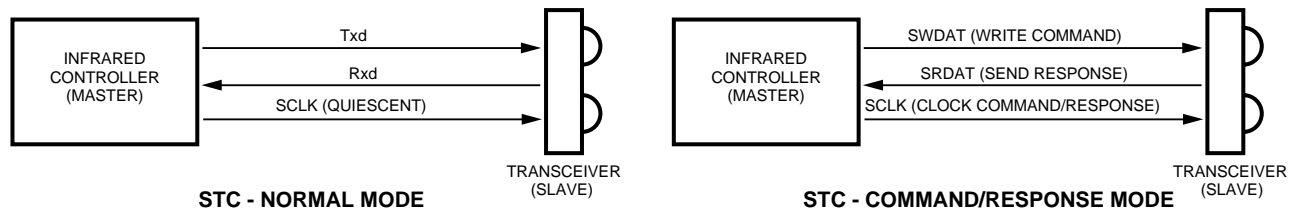

Figure 6.14 STC Modes.

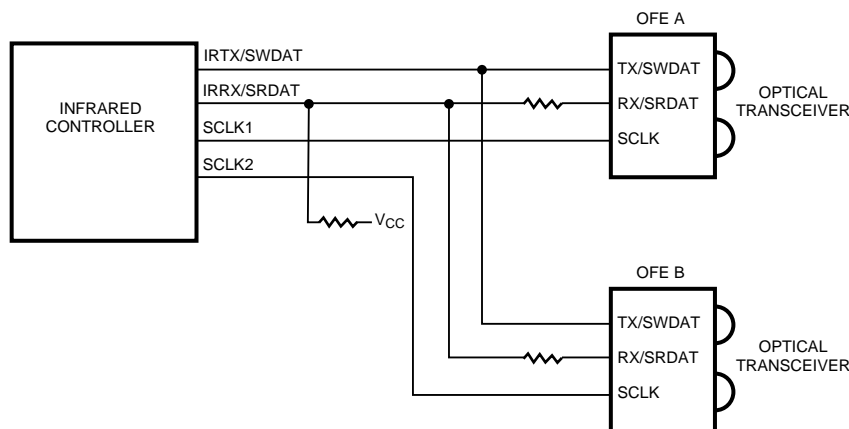

Figure 6.15 Addressing Scheme for Two Transceivers (short distance).

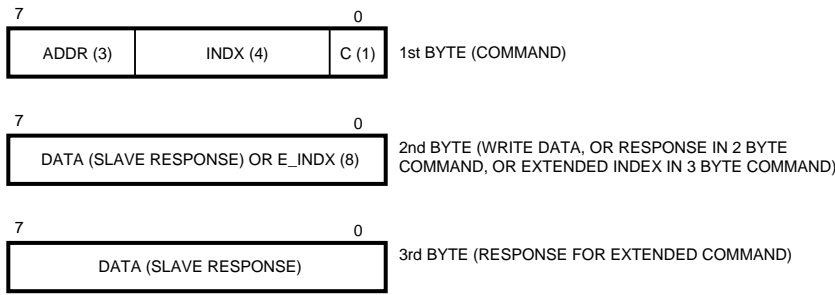

Figure 6.16 Command Format.

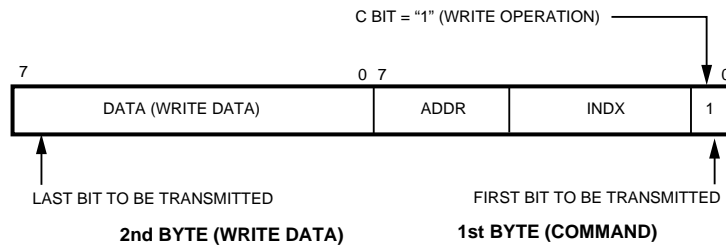

Figure 6.17a. Write Transaction Bitstream Representation (normal write transaction).

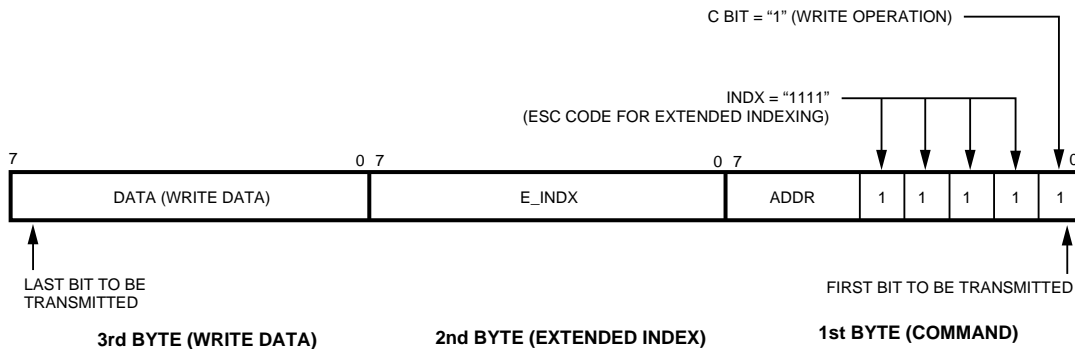

Figure 6.17b. Write Transaction Bitstream Representation (extended write transaction).

differentiate between different transceivers on the bus.

The following figures show the write and read transaction formats.

Figure 6.17 shows the write command. Note that the "C" bit is set to "1" to indicate a write transaction. The index field points to a particular register to write to (or read from, in the case of a read transaction).

Figure 6.18 shows both 2- and 3-byte read transactions. Note that the "C" bit is now set to "0". The response from the slave is the last byte of the transaction.

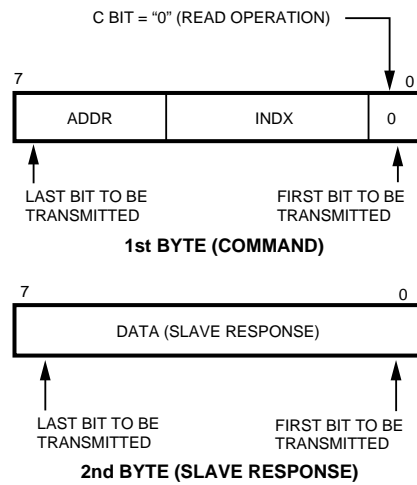

Figure 6.18a. Read Transaction Bitstream Representation (normal read transaction)

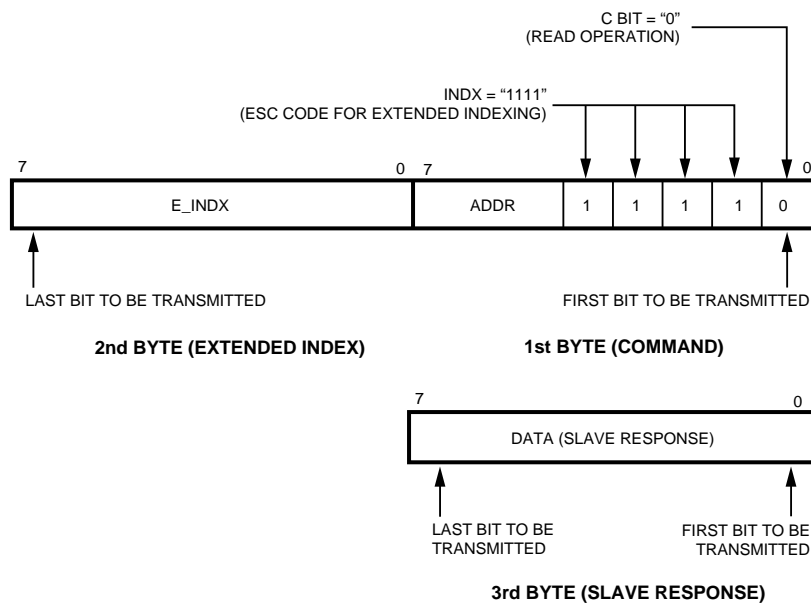

Figure 6.18b. Read Transaction Bitstream Representation (extended read transaction).

6.11 BUS TIMING

The bus timings are designed to be simple and to minimize the effects of timing skew. This section discusses some key points regarding the bus timings, then illustrates with waveforms of typical STC transactions.

Bus timing points to note

- A. Data is transferred in Little Endian order. That is, the LSB on the first byte is transmitted first, and the MSB of the 2nd or 3rd byte is transmitted last. This is illustrated in Figures 6.17 and 6.18.
- B. There are no gaps between bytes in the command or response phases.
- C. Each byte in the command and response phase is preceded by a start bit on the SCLK line.
- D. Data sampling and clocking:
 - i. Input data is sampled on the rising edge of SCLK
 - ii. Output data from the controller is clocked out on the falling edge of SCLK
 - iii. Output data from the slave is clocked out on the rising edge of SCLK
- E. The first low-to-high transition of SCLK indicates that an STC transaction is pending. On receipt of his rising edge, the slave will disable the LED. The next SCLK low-to-high transition indicates the start cycle, followed by the command phase (which the controller puts out on the SWDAT line). The LED needs to be disabled since TXD and SWDAT are multiplexed. If the LED were not disabled, then the LED will pulse according to the SWDAT bitstream.
- F. The LED is re-enabled (by the slave) on the last SCLK of the STC transaction bitstream. Normal infrared transmission can resume. No SCLK transitions should then take place until the next STC transaction otherwise the LED will be disabled (see above, the first low-to-high SCLK transition will cause the slave to disable the LED in preparation for an STC transaction).
- G. The response from the slave is carried on the SRDAT line, which is multiplexed with RXD. The detector is (internally) disabled by the slave during the response phase. This is to prevent stray IR transitions from corrupting the SRDAT bitstream.
- H. During a READ transaction, the controller holds the SWDAT line low for 1 clock after sending the ADDR and INDX byte (or bytes, if using Extended Index addressing).

It then holds it high and low again 3 clocks before the end of the transaction. This is a sure way for the transceiver to monitor the impending end of a transaction, rather than by counting pulses.
- I. When powered up, the transceiver is not ready to perform IR transmissions yet. The controller has to initialize the transceiver first. The power up sequence in brief:
 - i. On power up, an internally generated signal in the transceiver sets the 3 control registers:
 - a) Control register 0:
 - Bit 0: shutdown mode
 - Bit 1: RX disabled
 - Bit 2: LED disabled
 - b) Control register 1:
 - Bit 0-7: SIR mode
 - c) Control register 2:
 - Bit 0-7: Power at 100% level
 - d) At this point, the transceiver is not ready. Before issuing any commands, the controller has to initialize the transceiver by:
 - Hold SWDAT low
 - Toggle SCLK for at least 30 cycles.
 - The transceiver is now in STC mode and ready to accept STC transactions.

7. Design Guidelines

7.2 MECHANICAL CONSIDERATIONS

Agilent transceivers are available in various package mounting options. They are also designed for automatic placement. Different product families may require different handling and placement considerations due to the different packages used.

The HSDL-1xxx family supports through-hole or SMT mounting in front or top-view options. Mounting locations may be on the PCB or at the edge.

The other families (HSDL-2xxx, HSDL-32xx, HSDL-36xx,) are SMT mountable. They use castellations instead of leads. Castellations can be thought of as leads flush with the package side, and are implemented by cutting through a plated through hole in an axial plane.

The following sections cover the various packaging options, stor-

age and assembly instructions. The information is also available in the respective product data sheets.

Packaging Options

Lead Bend Options

The HSDL-1001 and HSDL-1100 come in a variety of lead bend options. These allow the optical axis to be perpendicular or parallel to the board (top and front mount respectively), or for the HSDL-1001 to straddle the middle of the board. Figures 7.1 and 7.2 illustrate the various lead bend options. The actual codes are given in the respective data sheets.

SMT Options

The SMT mountable transceivers comprise two main families, HSDL-2xxx and HSDL-3xxx. The HSDL-3xxx products use a technology known as “sheetcast”, and are an alternative to leadframe technology. The electronics are mounted on a miniature PCB. The electrical connections are brought out by castellations. The castellations can be described as plated through holes (PTH) sawn along the axis (refer to Figure 7.4). When reflowed, solder fills up the holes, and wicks up the vertical surfaces (land area before PTH was sawn through) to form a proper fillet.

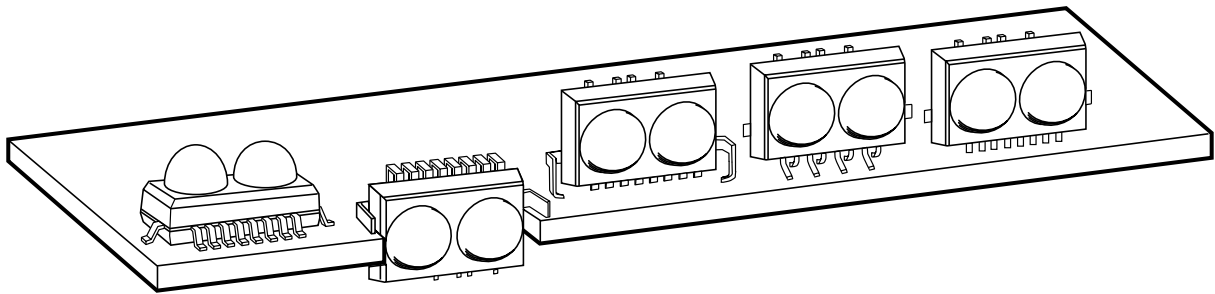

Figure 7.1 HSDL-1001 Mounting Options.

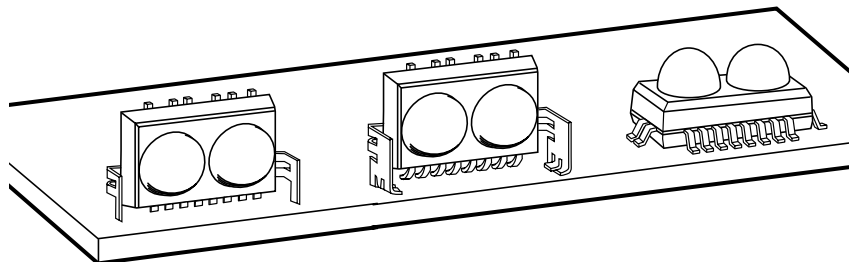

Figure 7.2 HSDL-1100 Mounting Options.

Sheetcast units can be identified by the PCB with a lens molded to form an integrated unit. The PCB will only be visible at the bottom for shielded options.

The HSDL-2xxx is a combination of discrete and sheetcast products. It can be treated as a sheetcast product in terms of mounting and reflow. These transceivers have mainly two directions of mounting, with the optical axis perpendicular or parallel to the PCB (top or front mount respectively). Certain products are available only in front mount, others have an option for guide pins (located at the side of the shield). Actual options are given in the respective product data sheets.

Figures 7.3 and 7.4 show front mount versions of the HSDL-2xxx and HSDL-33xx, viewed from the underside (i.e., viewed through an imaginary PCB). The castellations are at the front bottom of each photograph. Note that the relative size of the photographs is not to scale.

The HSDL-36xx family is available in top and front mount, with guide pins also available as a supplementary front mount option. These are illustrated in Figures 7.5 – 7.7.

The sheetcast units have the advantage of self-aligning during reflow. This can self-correct for x, y and theta displacements during mounting operations, thus opening up the SMT mounting process window.

Guide pins are provided as options after customer feedback. However, the self-aligning feature generally makes these unnecessary.

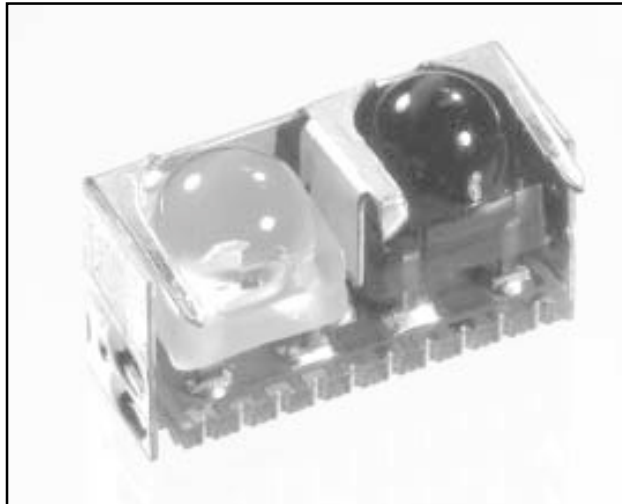

Figure 7.3 HSDL-2xxx Showing Guide Pins and Castellations.

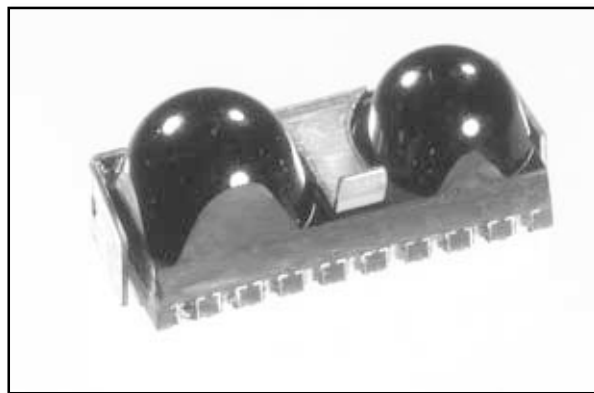

Figure 7.4 HSDL-33xx Front Mount, showing shield foot and castellations. Currently the HSDL-33xx is not available with guide pins.

If the guide pin location holes have a location offset error, the guide pins will provide a constraint to the self-aligning process. The resulting misaligned unit may suffer from problems such as pin-to-pin shorting, inter-pad shorting/solder bridging, insufficient wetting/fillet due to excessive x and/or y displacement, etc.

Due to the proximity of the guide pin to the extreme land pads for the HSDL-3600, PCB designers should use the guide pin only as a mechanical guide, and not solder

it. Given the typical tolerance stack up, there is a risk that solder bridging may occur between the guide pin land (if included) and the land for pins 1 or 10.

Tape and Reel

Agilent transceivers are shipped in tape and reel packaging. The reel increment is specified by a particular option (refer to actual product data sheet or selection guide). Larger sized transceivers, e.g. HSDL-1xxx and HSDL-2xxx, have increments of 10 and 200. The smaller sized transceivers, e.g. HSDL-32xx and HSDL-36xx,

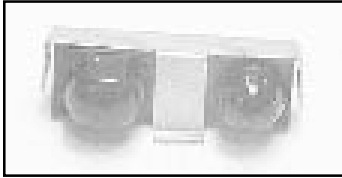

Figure 7.5 HSDL-36xx Front Mount Option.

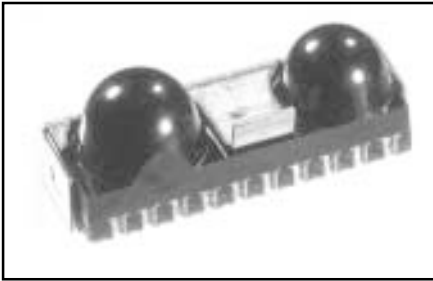

Figure 7.6 HSDL-36xx Top Mount Option.

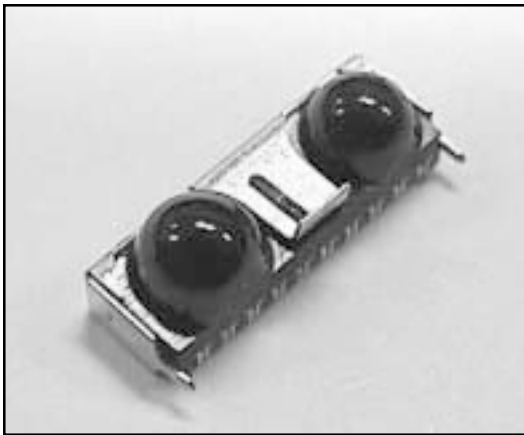

Figure 7.7 HSDL-36xx Front Mount Option with Guide Pins.

have increments of 10, 300, 400, 500 and 2500 units (not all products are available in all 5 increments). The increment size of 10 is shipped in strips of tape and reel.

Front mount units will have the flat shield top surface facing up and the lenses facing the right, assuming that the reel is unwound in a left to right direction. Top mount units will have the lenses facing up and the shield tab facing the right, again assuming that the reel is unwound in a left to right direction.

The cover tape is designed to hold the units securely within, yet peel off cleanly with a force of 10-70 g at 165-180 degrees along the longitudinal axis of the carrier tape, at a peel speed of 300 ± 10 mm/min.

Packaging and Mounting Options for Encoder/Decoder (endec) ICs

The HSDL-7000 and HSDL-7001 endecs are packaged as 8 and 16-pin SOICs respectively. These can be mounted and reflowed using standard SMT processes. Both products are presented in tape and reel. Reel increments are specified by options, currently at 2500 and 100 units.

Storage Recommendations

Agilent transceivers are encapsulated in standard industry mold compounds. These compounds are hygroscopic and the transceivers need to be kept in a dry environment prior to use. Recommended storage conditions are $<25^{\circ}\text{C}$ storage temperature and $<60\%$ relative humidity.

The transceivers are shipped in moisture barrier bags. When opened, moisture absorption begins. If the units are exposed to

the environment beyond **48 hours**, the units need to be baked to drive out moisture, and subsequently stored in a dry environment (with desiccant) if not mounted and reflowed.

The transceivers are baked as part of the assembly process. They are then sealed in moisture barrier bags, together with desiccant and a humidity indicator strip, prior to shipping. The humidity indicator strip will turn from blue to pink if the barrier bag has been breached and moisture has entered.

Delay opening the moisture barrier bags until just before reels are to be loaded onto the pick and place machine. Ensure that the placement and reflow operation is carried out within 48 hours from opening the bags.

The bake time/temperature settings are derived from experiments based on the IPC/EIAJ J-Std-020A joint industry standard, and are tabulated in Table 7.1.

Mechanism of Humidity-induced Failure

As mentioned before, the molding compound (encapsulant) is moisture permeable, by nature hygroscopic. SMT reflow is thermally more stressful on the device as soldering takes place on the same side of the PCB, unlike through hole devices where the soldering occurs on the other side of the PCB, thus the PCB offers some thermal shielding. In general, the SMT device also has a thinner layer of encapsulant between the (internal) chip mounting surface and the external mounting pad interface to the outside package surface.

Table 7.1: Bake Time / Temperature Settings

Product	Bake Time (hours) (includes oven ramp-up)	Bake Temperature (°C)
HSDL-1xxx	12 ± 0.5	100 ± 5
HSDL-32xx	≥ 48	60 ± 5
	≥ 4	100 ± 5
	≥ 2	125 ± 5
	≥ 1	150 ± 5
HSDL-33xx	≥ 48	60 ± 5
	≥ 4	100 ± 5
	≥ 2	125 ± 5
HSDL-36xx	≥ 48	60 ± 5
	≥ 4	100 ± 5
	≥ 2	125 ± 5

When the part is heated, the moisture vapor pressure increases rapidly. This causes a differential rate of expansion, which can cause internal delamination of the encapsulant from the die and/or leadframe/substrate. Other failures include internal cracks that do not extend to the package exterior, wire bond damage including breakage, separation of the bond from the die/leadframe or ball bond cratering.

More severe failures include external package cracks. This is known as a “popcorn” failure as the internal stresses can cause the package to bulge and then crack with an audible “pop”. In extreme cases, a portion of the die may even protrude from the package.

When the temperature ramp rate limit is exceeded or excessive heat is applied, the common failure modes seen are delamination and broken wires. Common causes are poor temperature control in ovens (e.g. overshoot at the maximum), or very hot soldering

irons used in rework exceeding the transceiver’s rated temperature limit.

More information can be found in the IPC/EIAJ J-Std-020A joint industry standard.

Assembly Recommendations

Stencil and Aperture Dimensions

A stencil of 0.152 mm (0.006") or 0.127 mm (0.005") is recommended for solder paste printing. This ensures sufficient solder paste volume, adequate “brick” aspect ratio, and prevents inter-pad shorting. Due to the different product sizes, please refer to the respective product data sheets for the corresponding length/width dimensions of the stencil openings.

The stencil length opening is longer than the actual land area, to ensure that sufficient solder paste is deposited. The stencil thickness cannot be increased as this is restricted by the “brick” aspect ratio, and may cause other

problems, e.g. slumping. Agilent's evaluations show that the solder pulls into the joint, and there is no solder balling.

Solder Paste

Based on calculations and evaluations, the recommended solder paste volumes are tabulated in Table 7.2. This recommendation is based on either no-clean or aqueous solder cream types, typically 60-65% solid content by volume.

Table 7.2 Recommended Solder Paste Volume.

Product	Solder paste volume/castellation (mm ³ , ± 15%)
HSDL-2xxx	0.36
HSDL-32xx	0.22
HSDL-33xx	0.30
HSDL-36xx	0.30

The solder paste volume is calculated using an approximated using a geometrical model of a castellation joint. As an example, the HSDL-36xx castellation solder fillet model is shown in Figure 7.8.

Pick and Place; Alignment Tolerance

A standard pick and place operation can be used. The transceiver should be picked up around the mounting center – this may not be coincident with the centerline of the shield foot, e.g. HSDL-36xx.

Pick and place can be performed using standard SMT machines. The flat top of the integrated shield makes it easy for vacuum pickup tools.

An evaluation of several popular pick and place machines was

done. The key factor to successful pickup was found to be the type of vision used – front or back lighting. The evaluation was based on HSDL-2300, HSDL-3200 and HSDL-3600. These are physically representative of the HSDL-2xxx, HSDL-32xx and HSDL-36xx families respectively (all three parts were run on each machine).

The findings can serve as a guide. However, it is recommended to verify this during setup. More detailed specifications on the pick and place machines can be obtained from the respective manufacturers.

It was found that the Siemens machine requires front lighting to recognize all three transceiver types. In the case of the Panasert, Fuji and Universal machines, the optimal vision methods are tabulated below. Although back lighting can be used for all three transceiver types, the results obtained weren't optimal.

The findings are summarized in Table 7.3.

Table 7.3: Pick and Place Machine Vision Lighting vs. Transceiver Type.

Brand	Model	Optimal Vision Method	
		Front lighting	Back lighting
Panasert	MPA-V, MPA-V2, MPA-G1	HSDL-3200, HSDL-3600	HSDL-2300
Fuji	QP242	HSDL-3200, HSDL-3600	HSDL-2300
Universal	GSM	HSDL-3200, HSDL-3600	HSDL-2300
Siemens	F4	HSDL-2300, HSDL-3200, HSDL-3600	Not applicable

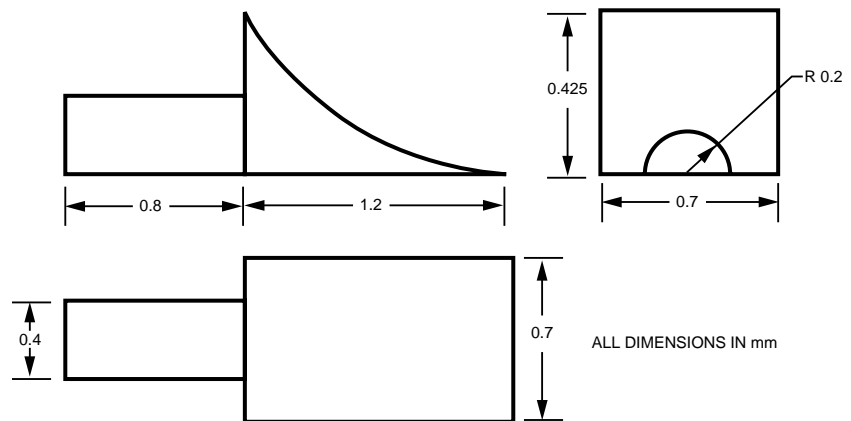

Figure 7.8 HSDL-36xx Front Mount Castellation Solder Fillet Model.

Placement Alignment Tolerance and Self-aligning

The unit will self-align during reflow provided sufficient solder paste is applied, and the misalignment is within the tolerance limits. The self-alignment takes place with the aid of the liquid solder surface tension. The self-aligning feature is independent of board direction travel (assuming convective reflow).

Figure 7.9 shows the co-ordinate system used when discussing placement. Note that only 50% of the land is shown, the remainder is under the transceiver. This is illustrated in Figure 7.10.

Castellation x-axis Alignment Tolerance

In general, during placement, the x-axis misalignment should not exceed 0.2 mm (0.008") or half the castellation width (whichever is smaller). Figures 7.11 and 7.12 show the placement of the transceiver before reflow (x-axis misalignment), and the position after reflow and self-alignment.

Castellation y-axis Alignment Tolerance

In general, the unit does not self-align in the y-axis. Agilent recommends that the unit be placed in line with the fiducial mark. The intention is to leave a minimum of 50% of the land length exposed, ensuring a good fillet. Refer to Figure 7.10.

Castellation Rotational (θ) Alignment Tolerance

The rotational alignment tolerance varies by product, and also by front/top mount. The values are summarized in Table 7.4. Refer to the product data sheet for the authoritative figures, as these are subject to improvement and change.

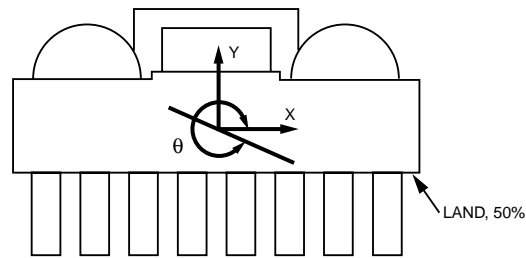

Figure 7.9 Co-ordinate System for Placement (front mount, plan view).

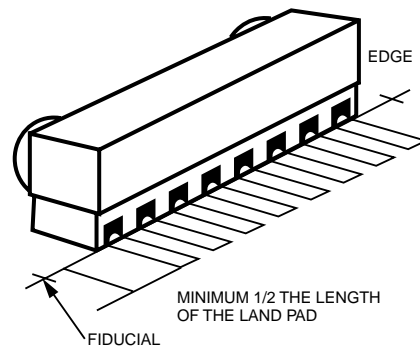

Figure 7.10 Recommended Transceiver Placement with Respect to Land Pattern.

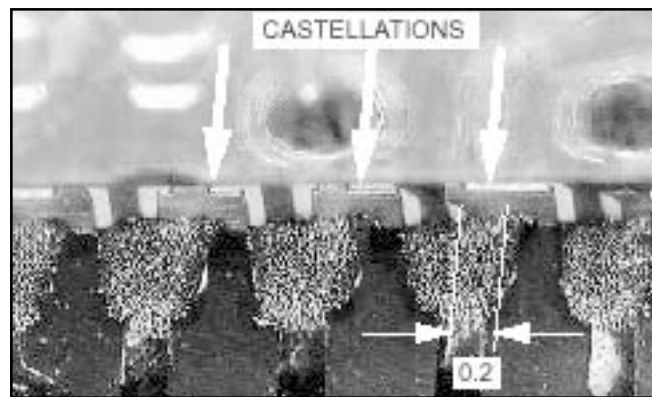

Figure 7.11 x-axis Misalignment, before Reflow.

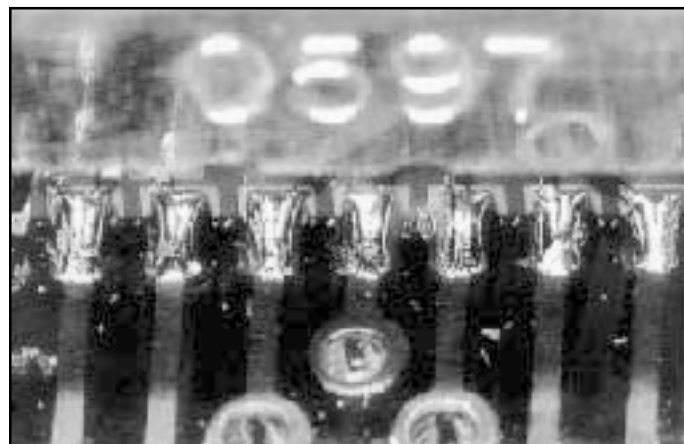

Figure 7.12 x-axis Misalignment Self-corrected after Reflow.

Table 7.4 Placement Alignment Tolerances.

Product	Alignment tolerance (mm or degrees)			Mount option
	X-axis	Y-axis	θ	
HSDL-2100, HSDL-2300	0.2 mm or half castellation width	Place in line with fiducial	$\leq \pm 3^\circ$	Front mount
HSDL-3200	0.2 mm or half castellation width	Place in line with fiducial	$\leq \pm 3^\circ$	Front mount
HSDL-3201	0.2 mm or half castellation width	Place in line with fiducial	$\leq \pm 3^\circ$	Front mount
HSDL-3202	0.2 mm or half castellation width	Place in line with fiducial	$\leq \pm 3^\circ$	Front mount
HSDL-3310	0.2 mm or half castellation width	Place in line with fiducial	$\leq \pm 2^\circ$	Front mount
HSDL-3600#007, #017	0.2 mm or half castellation width	Place in line with fiducial	$\leq \pm 2^\circ$	Front mount
HSDL-3600#107, #117	0.2 mm or half castellation width	Place in line with fiducial	$\leq \pm 2^\circ$	Front mount with guide pins
HSDL-3600#008, #018	0.2 mm or half castellation width	Place in line with fiducial	$\leq \pm 1^\circ$	Top mount

Reflow Profile

Soldering IR transceivers, which are lightweight miniature components, in a mass manufacturing environment can pose serious process problems. It is imperative that the recommended respective reflow profiles be strictly adhered to for every transceiver. IR transceivers can be reflow soldered using a convective IR process. A convective IR process uses middle to long infrared wavelengths (approximately 4000 to 6200 nanometers). Approximately 65% of the energy is used to heat the air in the reflow chamber (convective heating) and 35% of the energy directly heats the PC board and components (radiative heating). Some systems are forced hot air systems with a dual chamber design, wherein the first chamber has IR heaters to heat the air which is then blown over the PC board assemblies located in a second chamber. In these sys-

tems, heating is 100% convective. The PC board and components are uniformly heated to achieve reliable solder connections. A convective thermal environment minimizes the thermal stresses experienced by the component.

Figure 7.13 is a straight-line representation of a nominal temperature profile for a convective reflow solder process. All temperature and time values indicated are for illustration

purposes only. Please follow the respective reflow profile stated for every transceiver in their respective data sheets. The temperature profile is divided into four process zones with four $\Delta T/\Delta \text{time}$ temperature change rates. The $\Delta T/\Delta \text{time}$ temperature change rates are detailed in Table 7.5. The temperatures are measured at the component to printed circuit (PC) board connections.

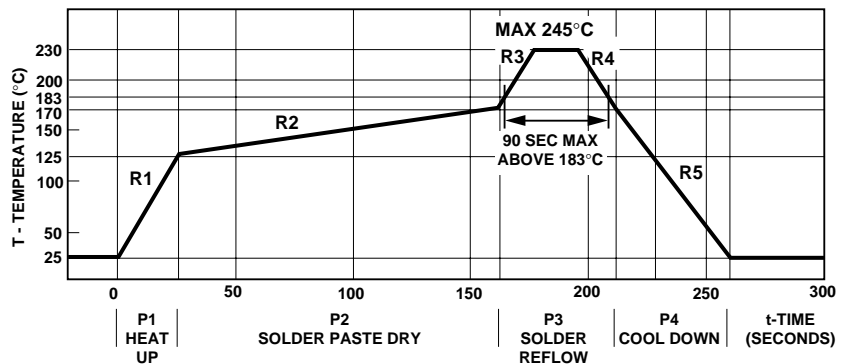

Figure 7.13 Reflow Profile.

In **process zone P1**, the PC board and the transceiver castellation I/O pins are heated to a temperature of 125°C to activate the flux in the solder paste. The temperature ramp up rate, R1, is limited to 4°C per second to allow for even heating of both the PC board and transceiver castellation I/O pins.

Process zone P2 should be of sufficient time duration (> 60 seconds) to dry the solder paste. The temperature is raised to a level just below the liquidus point of the solder, usually 170°C (338°F).

Process zone P3 is the solder reflow zone. In zone P3, the temperature is quickly raised above the liquidus point of solder to 230°C (446°F) for optimum results. The dwell time above the liquidus point of solder should be between 15 and 90 seconds. It usually takes about 15 seconds to assure proper coalescing of the solder balls into liquid solder and the formation of good solder connections. Beyond a dwell time of 90 seconds, the intermetallic growth within the solder connections becomes excessive, resulting in the formation of weak and unreliable connections. The temperature is then rapidly reduced to a point below the solidus temperature of the solder, usually 170°C (338°F), to allow the solder within the connections to freeze solid.

Process zone P4 is the cool down after solder freeze. The cool down rate, R5, from the liquidus point of the solder to 25°C (77°F) should not exceed -3°C per second maximum. This limitation is necessary to allow the PC board and transceiver castellation I/O pins to change dimensions evenly, thereby minimizing the stress on the transceiver.

Table 7.5 Convective IR Reflow Process Zones, see Figure 7.13.

Process Zone	Symbol	ΔT	Max. ΔT / Δtime
Heat Up	P1, R1	25°C to 125°C	4°C/s
Solder Paste Dry	P2, R2	125°C to 170°C	0.5°C/s
Solder Reflow	P3, R3	170°C to 230°C (245°C max.)	4°C/s
	P3, R4	230°C to 170°C	-4°C/s
Cool Down	P4, R5	170°C to 25°C	-3°C/s



Figure 7.14 Good Solder Joint.

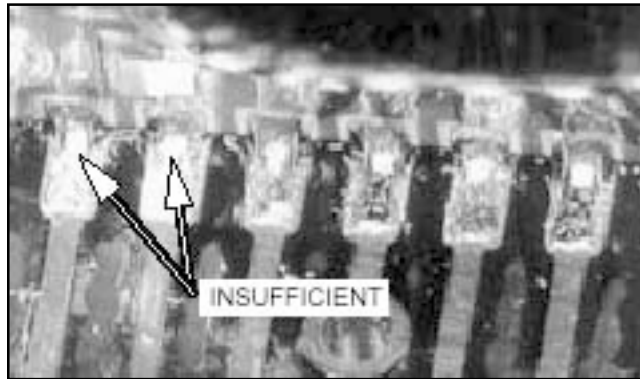

Figure 7.15 Insufficient Solder.

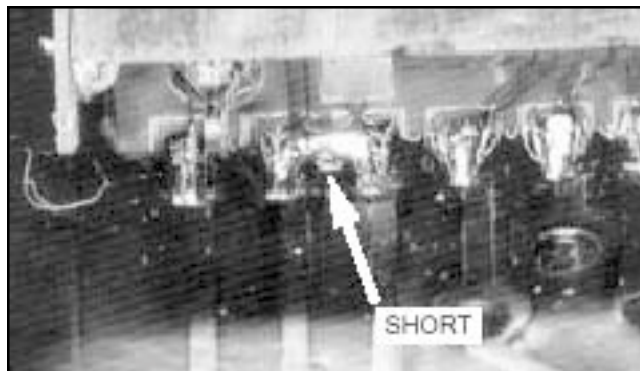

Figure 7.16 Solder Bridging (shorted)

Examples of Castellation Solder Joints

Figures 7.14 - 7.16 show solder joints which are good, insufficient solder, and solder bridging

(shorted). This can be used as a starting point for post reflow visual inspection.

Other SMT Considerations

Nitrogen vs. air reflow

All evaluations have been done using air as the reflow environment. No problems have been observed that require nitrogen reflow, since the transceivers were first introduced (volume shipped is in the hundreds of millions of units).

Lead-free soldering process

At time of this writing, Agilent Technologies' transceivers are not lead-free (Pb-free), nor are they compatible with lead-free reflow processes yet. Re-designs and evaluations are in progress to meet industry and regulatory/legislative deadlines.

7.2 ELECTRICAL CONSIDERATIONS

Board Layout Guidelines

All IR modules contain high gain, wide bandwidth circuits. Special attention must be paid when designing and laying out boards with such components. As with many analog components, efforts should be made to separate the IR module from sources of electromagnetic noise (EMI), and to minimize power supply and ground line noise. The effects of EMI and power supply noise can potentially reduce the sensitivity of the receiver, resulting in reduced link distance. EMI can also generate spurious signals on the receiver RXD output when no IR signal is being received. Evaluation kits which demonstrate the recommended board layout for each transceiver model are available, and can be obtained from your local Agilent Component Sales Representative. These kits are further described on page 55.

EMI Immunity

EMI is radiated by switched mode power supplies, dc/dc converters, external monitor I/O ports, power ports, or clock generators. The voltage of the EMI source and the distance from the source determine the strength of the EMI field at any given point. EMI field strength is measured in Volts/meter. A 200 V source placed one meter from a detector represents a field strength of 200 V/m. Similarly, a 10V source at a distance of 5 cm also represents a field strength of 200 V/m.

An IrDA receiver's EMI immunity is the maximum EMI field strength that the receiver can tolerate while maintaining a bit error rate (BER) $< 10^{-8}$. **All Agilent transceivers are shipped with a metal shield as standard or option, and have EMI immunity typically greater than 200 V/m.** Thus the distance of the EMI source to the module must be increased so that the EMI field strength is less than 200 V/m at the transceiver module.

Power Supply Rejection (PSR)

Power supply noise can be coupled into the receiver through V_{CC} or ground lines. Power supply ripple is a common example of power supply noise. Power Supply Rejection (PSR) refers to the module's ability to tolerate power supply noise, while maintaining error free operation. Proper PCB layout techniques and external component placement can ensure successful operation with power supply noise present on V_{CC} or ground.

Board Layout Recommendations

The following recommendations for PCB layout should provide sufficient EMI immunity and power supply rejection for error free IR link operation. Please see Agilent Application Note 1114, "Infrared Transceiver PC Board Layout for Noise Immunity".

- **Board Topology:** A multi-layer PC board is recommended so that a sufficient ground plane can be properly placed. Use one layer underneath and near

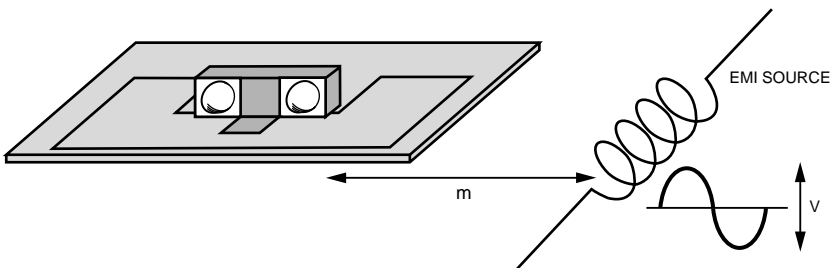

Figure 7.18 Noise and Distance Relationship.

the transceiver module as V_{CC} , and sandwich that layer between ground connected board layers. For example in a four layer board, layer 1 (top) contains signal traces, layer 2 contains ground underneath the module and surrounding areas, layer 3 contains traces, data bus signals and V_{CC} , layer 4 (bottom) contains ground metal.

The area underneath the module *at the second layer*, and 3 cm in any direction around the module is defined as the **critical ground plane zone**. The board ground plane should be maximized in the critical ground plane zone. Any unused board space in the critical ground plane zone should be filled with ground metal. **Do not connect this ground plane directly to the IrDA module ground pin. Additionally, any fast switching data or clock signals at the layer 3 should not be laid directly underneath the critical ground plane zone.** Figure 7.19 illustrates the above points.

- **External Components and Integrated shield:** *Bypass capacitors for the V_{CC} pin should be of low inductance and wide frequency response, e.g. X7R ceramic, while that for the VLED pin should be of big volume and fast frequency response, e.g. Tantalum.* Both should be placed as close (<0.5 cm) to the V_{CC} and GND pins of the module, and on the same side of the board as the module. The remaining components should be placed within the board area where the ground plane has been maxi-

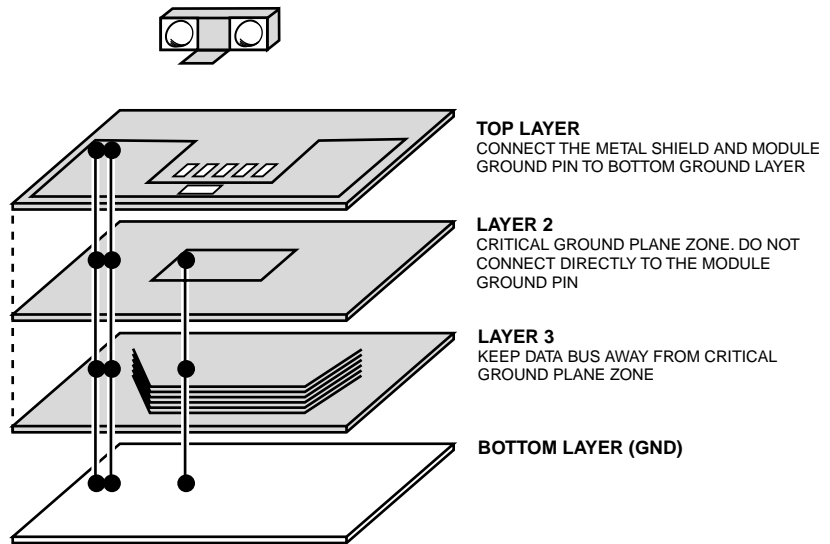

Figure 7.19 Board Topology and Layer Design.

mized. **The integrated metal shield of the module should be connected to the ground plane by the shortest path.**

- **V_{CC} Supply:** The least noisy power source available on the application board should be chosen for V_{CC} of the module. Biasing V_{CC} directly from a noisy switched mode power supply line should be avoided. The V_{CC} line to the transceiver module should be filtered sufficiently so that less than 75 mV of noise is present at either the V_{CC} or GND pins of the module. The recommended values of the V_{CC} bypass capacitors should provide sufficient filtering in most cases, but may be increased in value if more filtering is necessary.

- **Proximity to Noise Sources:** All signal or noise sources (power ports, monitor ports, clock generators, switched mode power supplies) should be placed as far away as possible to minimize EMI at the module. Distance to noise sources should be considered in all dimensions, including other circuit boards that may be either above or below the transceiver module, or flex circuits (with a noise source) “folded” close to the module during the final assembly.

Reference Layout

Reference schematics for each of the transceiver families are shown in the diagrams below along with the recommended component values.

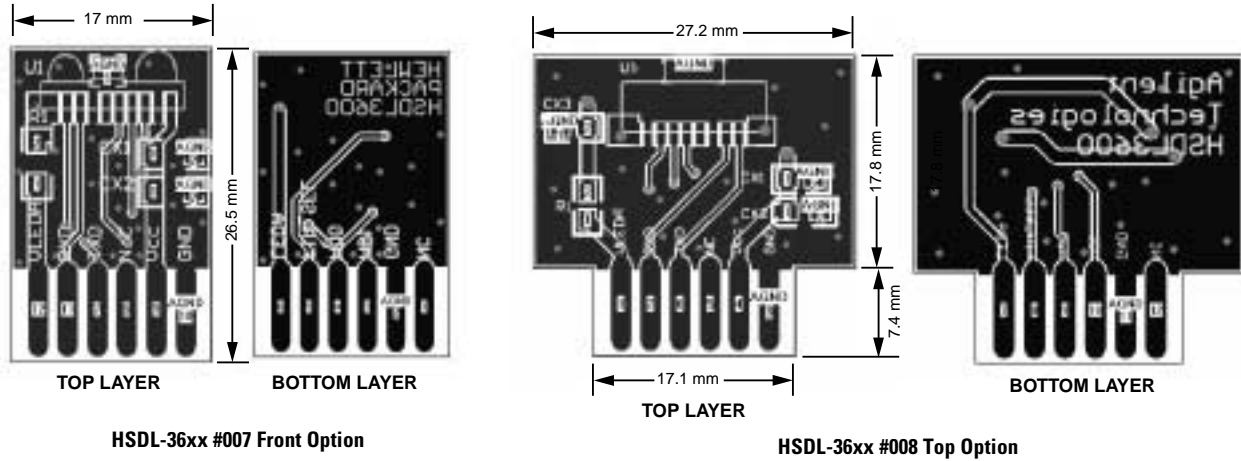

HSDL-3600 #007 / HSDL-3600 #008

Components	Recommended Value
R1	2.2 Ω , $\pm 5\%$, 0.5 W, for 2.7 V $\leq V_{CC} \leq 3.3$ V operation 2.7 Ω , $\pm 5\%$, 0.5 W, for 3.0 V $\leq V_{CC} \leq 3.6$ V operation
CX1	0.47 μF , $\pm 20\%$, X7R Ceramic
CX2	6.8 μF , $\pm 20\%$, Tantalum
CX3	6.8 μF , $\pm 20\%$, Tantalum

HSDL-3601 #007 / HSDL-3601 #008

Components	Recommended Value
R1	6.2 Ω , $\pm 5\%$, 0.5 W, for 4.75 V $\leq V_{CC} \leq 5.25$ V operation
CX1	0.47 μF , $\pm 20\%$, X7R Ceramic
CX2	6.8 μF , $\pm 20\%$, Tantalum
CX3	6.8 μF , $\pm 20\%$, Tantalum

HSDL-3610 #007 / HSDL-3600 #008

Components	Recommended Value
R1	6.2 Ω , $\pm 5\%$, 0.5 W, for 2.7 V $\leq V_{CC} \leq 3.6$ V operation 15.0 Ω , $\pm 5\%$, 0.5 W, for 4.75 V $\leq V_{CC} \leq 5.25$ V operation
CX1	0.47 μF , $\pm 20\%$, X7R Ceramic
CX2	6.8 μF , $\pm 20\%$, Tantalum
CX3	6.8 μF , $\pm 20\%$, Tantalum

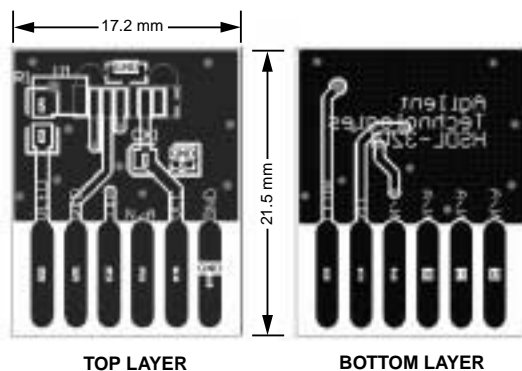

HSDL-3201

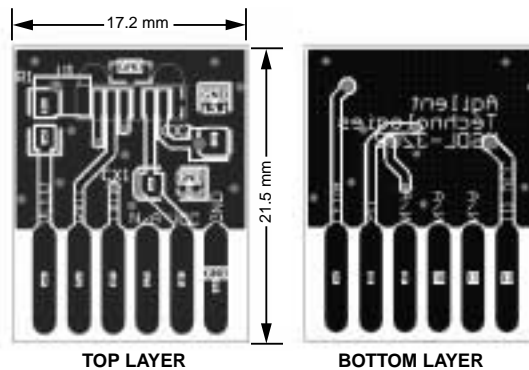

HSDL-3202

HSDL-3201

Components	Recommended Value
R1	0 Ω , $\pm 5\%$, 0.5 W
CX1	1 μF , $\pm 20\%$, Tantalum

HSDL-3202

Components	Recommended Value
R1	0 Ω , $\pm 5\%$, 0.5 W
CX1	1 μF , $\pm 20\%$, Tantalum
CX2	1 μF , $\pm 20\%$, Tantalum

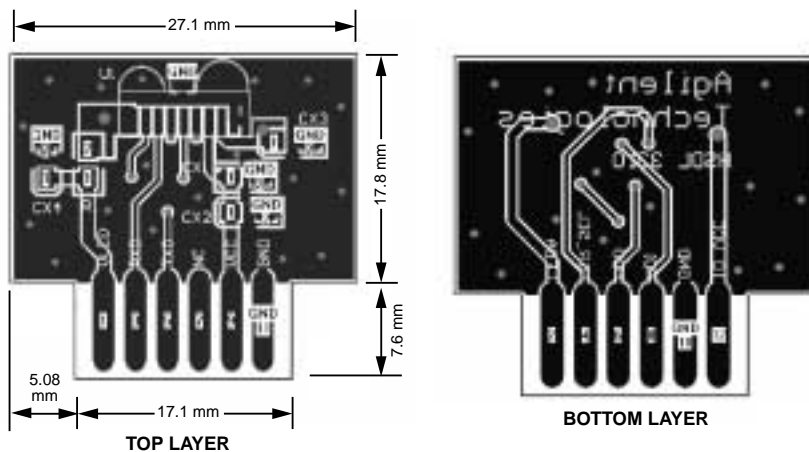

HSDL-3310

HSDL-3310

Components	Recommended Value
R1	2.2 Ω , $\pm 5\%$, 0.5 W, for 2.7 V $\leq V_{CC} \leq 3.3$ V operation 2.7 Ω , $\pm 5\%$, 0.5 W, for 3.0 V $\leq V_{CC} \leq 3.6$ V operation 5.6 Ω , $\pm 5\%$, 0.5 W, for 4.5 V $\leq V_{CC} \leq 5.5$ V operation
CX1	0.47 μF , $\pm 20\%$, X7R Ceramic
CX2	6.8 μF , $\pm 20\%$, Tantalum
CX3	1 μF , $\pm 20\%$, Tantalum
CX4	1 μF , $\pm 20\%$, Tantalum

7.3 OPTICAL PORT DESIGN

To ensure IrDA compliance, there are constraints on the height and width of the optical port. Minimum dimensions ensure that the IrDA cone angles are met, and maximum dimensions ensure that the effects of stray light are minimized. Usually the smallest possible window is wanted to minimize the opening in the product, and also due to the constraint the product manufacturers have on space. The minimum-viewing angle that will ensure that the IrDA cone angles are met without vignetting is ± 15 degrees. The minimum size corresponds to a cone angle of 30 degrees, the maximum to a cone angle of 60 degrees.

Figure 7.20 shows a module positioned with respect to the front panel of a hypothetical product. Dimension 'Z' is the distance between the apex of the receiver side lens and the back of the window. 'X' is the width of the window and 'Y' is the height of the window. 'K' is the distance of the center of the LED lens from the center of the photodiode lens. 'D' is the depth of the LED image inside the part, and 'A' is the half angle of the cone with a IrDA minimum of 15 degrees, and a maximum of 30 degrees.

For all transceivers, 'Z' is the distance specified by the optical window designer, and 'D' is the depth of the LED image that is provided by the IR Transceiver manufacturer. While computing the window dimensions, the thickness of the window can be assumed to be negligible. If the thickness of the window is taken into account, the optical thickness is the mechanical thickness divided by the index of reflection.

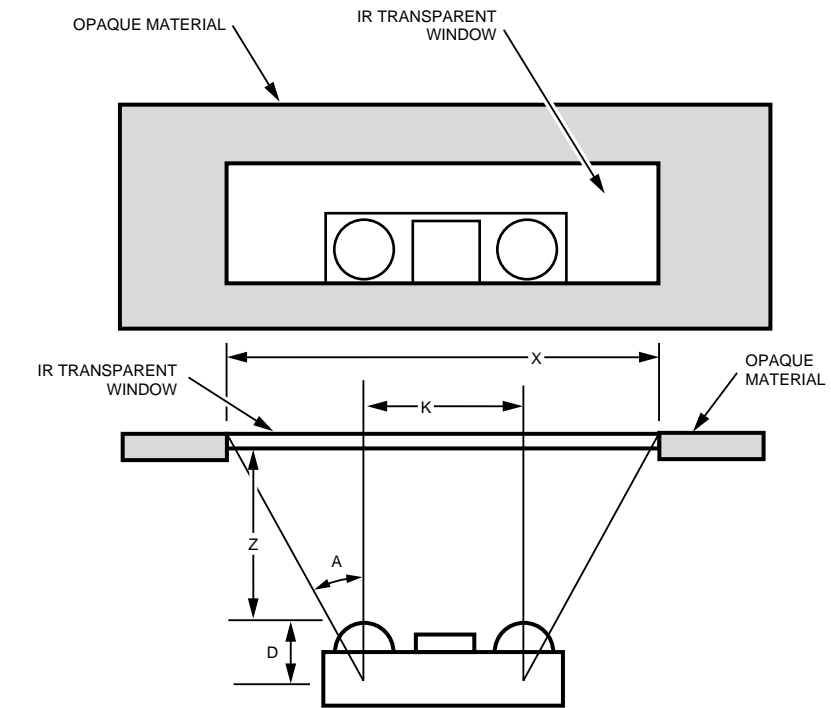

Figure 7.20 Position of Module with Respect to Product Case.

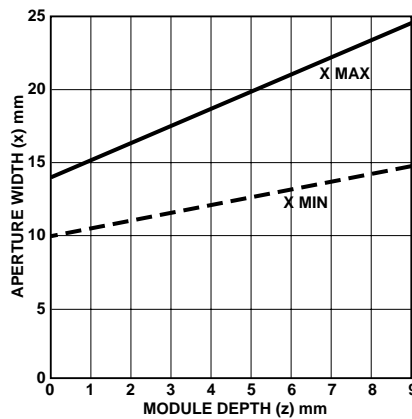

Figure 7.21: Aperture width (x) vs. module depth.

The width and height of the optical port can be calculated from the following expressions,

$$X = K + 2 \cdot (Z + D) \cdot \tan A$$

$$Y = 2 \cdot (Z + D) \cdot \tan A$$

The minimum and maximum value for the width and height is

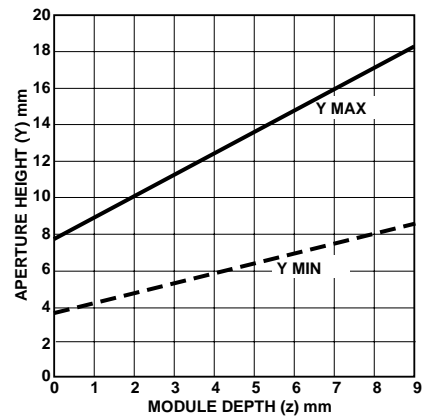

Figure 7.22: Aperture height (y) vs. module depth.

defined by the minimum and maximum viewing angle requirement of IrDA. Tangent A is the required half angle for viewing. For the IrDA minimum, it is 15 degrees, for the IrDA maximum it is 30 degrees. Figure 7.21 and figure 7.22 show the possible range of X and Y dimensions for a given module depth, Z.

Table 7.6 lists the distance from the center of the LED lens to the center of the photodiode lens 'K', and the depth of the LED image inside the part for the various Agilent IrDA transceivers.

Shape of the Window

From an optics standpoint, the window should be flat. This ensures that the window will not alter either the radiation pattern of the LED or the receiver pattern of the photodiode.

If the window must be curved for mechanical design reasons, place a curve on the backside of the window that has the same radius as the front side. While this will not completely eliminate the lens effect of the front curved surface, it will reduce the effects. The amount of change in the radiation pattern is dependent upon the material chosen for the window, the radius of the front and back curves, and the distance from the back surface to the transceiver. Once these factors are known, a lens design can be made which will eliminate the effect of the front surface curve.

The following diagrams show the effects of a curved window on the radiation pattern. In all cases, the center thickness of the window is 1.5 mm, the window is made of polycarbonate plastic, and the distance from the transceiver to the back surface of the window is 3 mm.

Window Material Selection

Agilent IrDA Transceiver specifications for transmitter radiant intensity and for receiver input irradiance allow for 10% light signal loss through a cosmetic window placed in front of the IR transceiver module. The recommended plastic materials for use

Table 7.6 Agilent Transceiver Image Depth

Agilent IrDA Transceiver	Distance between center of LED lens to center of photo-diode lens 'K' (mm)	Depth of LED image 'D' (mm)
HSDL-1001/1100	6.35 mm	6.70 mm
HSDL-3200/3201/3202	5.10 mm	3.17 mm
HSDL-3600/3601/3610	7.07 mm	8.00 mm
HSDL-2100/2200/2300	6.40 mm	7.00 mm

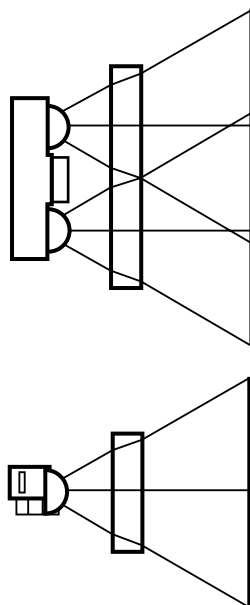

Figure 7.23 Flat Window (First Choice).

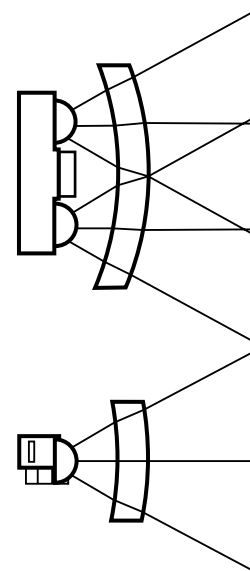

Figure 7.24 Curved Front and Back Window (Second choice).

as a cosmetic window are available from General Electric Plastics.

Recommended Dye: Violet #21051 (IR transmissant above 625 nm)

Indenting the module into the system box can attain improved receiver performance in the presence of ambient light (sunlight, fluorescent light, incandescent light) by a few millimeters. The overhang of the system box will minimize the amount of direct ambient light that the IrDA transceiver detector sees. The cosmetic window will also help reflect ambient light away from the module.

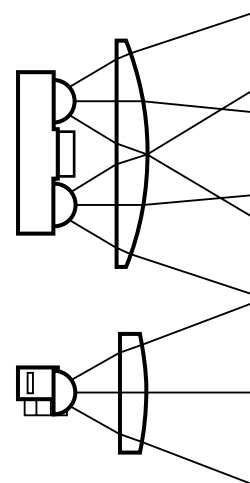

Figure 7.25 Curved Front, Flat Back Window (Not Used)

7.4 EYE SAFETY

Products compliant with or merely interoperable under the Infrared Data Association (IrDA) specifications 1.3, are also required to be eye safe, and in some geographical regions, compliant with national, regional or international eye safety standards. Agilent's IrDA transceivers are defined as eye safe based on compliance with the basic laser safety standard (IEC825-1), set by the Technical Commission 76, Laser Equipment (TC76) of the International Electrotechnical Commission (IEC). The European Committee for Electrotechnical Standardization (CENELAC) has also adopted this as EN 60825-1.

Infrared, visible or ultraviolet electromagnetic radiation, in sufficient concentrations, can cause damage to the human eye. To date, light-emitting diodes (LEDs), such as the ones used in IrDA transceivers, have not been found to cause any damage. But with the increase in LED efficiency and power with higher data rates and link distances, it is critical to keep a watchful eye on this parameter. Being a market leader in developing new transceivers, Agilent evaluates compliance with eye safety standards for every transceiver in the market. Agilent transceivers are designed to comply with the eye safety standards under all conditions.

The human eye can withstand only a finite amount of radiation, beyond which it can be irreversibly damaged. With this information, damage threshold levels have been calculated over a wide range of wavelengths and other relevant parameters. Given the damage threshold data, applying a safety factor enables the calculation of a set of Maximum

Permissible Exposures (MPEs). For a set of conditions, the MPE is the maximum electromagnetic radiation exposure that is deemed to be safe. A source that is deemed to be safe to the naked eye can turn harmful in the presence of light collecting/focussing optics. Hence, for a given method of viewing a set of Accessible Emission Levels (AEL) is calculated. AEL represents the amount of electromagnetic emission that is accessible by a human eye. AEL class limits are usually expressed in Watts or Joules. AEL is dependent on the system's light output power, wavelength, apparent source size and pulse or exposure duration.

System classification as eye safe or not is done in the following steps:

- Based on MPE in IEC825-1, calculate the AEL Class 1 limit. AEL class 1 limits for IrDA systems emitting short infrared pulses or continuous infrared light is shown in Table 7.8 below for different source sizes.

- Measure the actual AEL of the system (refer to Agilent Application Note 1118: Compliance of Infrared communication products to IEC 825-1 and CENELEC EN 60825-1).
- Measure the actual AEL of the system.
- Compare the AEL of the system with the AEL Class 1 limit for both pulsed emission and continuous emission.
- Consider operating conditions which may cause a single fault. If a single fault condition can cause increased emission, make sure that the AEL classification takes this into account.

The measurement distance, r , and measurement aperture diameter, d , are derived from apparent source size, s , as shown in Table 7.7. Apparent source size is how large the source appears (not the actual size of the emitter chip or the molded lens diameter).

Table 7.7

Aperture Diameter (d)	Measurement Distance (r)
Fixed at 7.0 millimeters	$100 (s/10 + 0.0046)^{0.5}$ millimeters
$7 (s/10 + 0.0046)^{-0.5}$ millimeters	Fixed at 100 millimeters

IEC 825-1 and EN 60825-1 regulations mention several AEL class limits. For source wavelength $\lambda = 700 - 1050$ nm, the AEL class 1 limit is calculated as:

$$\text{AEL} = [0.0007t^{0.75} C_4 C_6 \text{ Joules}] [1000 / t] \text{ milliwatts}$$

where,

t = exposure duration in seconds

$$C_4 = 10 [0.002 (\lambda - 700)]$$

$$C_6 = 1 \text{ for } \alpha < \alpha_{\min}$$

$$C_6 = \alpha / \alpha_{\min} \text{ for } \alpha_{\min} < \alpha < \alpha_{\max}$$

$$C_6 = 100 / \alpha_{\min} \text{ for } \alpha > \alpha_{\max}$$

where $\alpha = 1000 \cdot [12 \cdot \tan^{-1} ([s / 2] / 100 \text{ mm})]$ (milliradians)

s = apparent source size (millimeters)

The angular subtense parameter α_{\max} is defined as 100 milliradians. $\alpha_{\max} = 100$ mr is taken as the largest reasonable subtense which can be sharply focussed by a human eye. The apparent source angular subtense α_{\min} is the limit above which the source is considered an extended source. Because of eye movement, this is a function of time.

$$\begin{aligned} \alpha_{\min} &= 1.5 \text{ milliradians for } t < 0.7 \text{ seconds} \\ &= 2.0 t^{0.75} \text{ milliradians for } 0.7 \text{ seconds} < t < 10 \text{ seconds} \\ &= 11.0 \text{ milliradians for } t > 10 \text{ seconds} \end{aligned}$$

The AEL Class 3A limit is 5 times the Class 1 limit.

Table 7.8 AEL Limit Calculations (Wavelength $\lambda = 870$ nm in all cases)

Exposure Duration (t sec)	Apparent Source Size (s mm)	Angular Subtense (α milliradians)	AEL Class 1 limit (mW)
10	2	20	1.566
100	2	20	0.880
10	3	30	2.349
100	3	30	1.321

For more information on AEL classifications, class limit calculations, measurement of system AEL and AEL calculations for Agilent transceivers, please refer to Agilent Application Note 1118: *Compliance of Infrared Communication Products to IEC825-1 and CENELEC EN 60825-1*.

8. Evaluation and Developer Kits

Agilent's evaluation and developer kits provide the necessary information and components required to design and test an optimum IrDA compliant infrared system, which can later be incorporated into the final product. These kits allow a developer to experiment with the IrDA physical layer, evaluate the EMI effects on the performance, and understand the features and functions of Agilent transceiver modules. The evaluation boards serve as a reference to the recommended design and layout techniques described in this design guide and can be used for custom layout. With these kits, development time of the physical layer is greatly reduced by the provision of known good transceivers, so a link can be up and running quickly. The boards are ready to be plugged into an I/O device.

Table 8.1.

	HSDL-8000 Evaluation Kit	HSDL-8010 Evaluation Kit
HSDL-1001 on Evaluation Board	X	NA
HSDL-1100 on Evaluation Board	NA	X
HSDL-7001	X	NA
HSDL-4220	X	NA
HSDL-4230	X	NA
Data-sheet/Design Guide/Instruction	X	X

Developer Kit (HSDL-8000)

The HSDL-8000 evaluation kit includes two evaluation boards with the HSDL-1001 IrDA 1.0 Compliant Infrared transceiver for 115.2 Kb/s links. For serial port applications, the boards can be readily plugged to the port via the HSDL-7001 IrDA 1.0 Encode/Decode IC, which comes with the kit. Discrete IR LEDs are included in these kits for extending link distance or achieving greater viewing angles for non-IrDA links.

Developer Kit (HSDL-8010)

The HSDL-8010 evaluation kit includes two evaluation boards with the HSDL-1100 IrDA 1.1 Compliant Infrared transceiver for 4 Mb/s links. This kit provides the necessary information and components to assist you in designing an optimum 4 Mb/s IrDA Infrared system.

9. Beyond IrDA

9.1 EXTENDING TRANSMISSION DISTANCE

IrDA specifications specify a transmission link distance of 1 m for standard operation and 20 - 30 cm for low power operation. In some cases, it may be desired to increase link distance beyond the 1 m guaranteed by IrDA. Referring back to the section on “Introduction to Optics”, it can be seen that for an IR link between A and B, increasing both the intensity and sensitivity for A or B increases the link distance. Increasing either the intensity or sensitivity for both A and B can achieve the same results. The former arrangement is ideal for cases where the link distance with IrDA 1 m compliant devices is to be increased. All changes can be localized to one end of the link with no changes at the other. If at end A only the transmission intensity were to be increased, the same should be done at B as well. Otherwise, at distances greater than the guaranteed 1 m, it is quite possible that B is able to read the signals from A, but A is not able to read B due to B’s lower transmission intensity. The same logic can be extended to increasing sensitivity of the detector alone.

Typical link distance can be increased if both ends of the IR link increase their transmission intensity. Radiant intensity is approximately proportional to the LED forward current, and irradiance (the strength of the received

IR signal) will follow the inverse square law for distances greater than a few cm. For example, four times the LED forward current will provide four times the intensity. Four times the intensity will give the same signal strength at two times the distance. If a transceiver operating at 250 mA LED current can operate up to 1.6 m, an increase of LED current to 500 mA can improve the link distance to 2.2 m.

The HSDL-1001 featured in the example has the ability to drive an external LED for added power. Either the HSDL-4220 or the HSDL-4230 IR emitter can be connected in series or in parallel with the HSDL-1001’s internal LED. (Note that the parallel connection will only work with 5 V supplies.) The HSDL-4220 typically provides 190 mW/Sr of intensity at a peak pulse current of 250 mA, and has a viewing angle of 30 degrees. The HSDL-4230 typically provides 375 mW/Sr of intensity at a peak pulse current of 250 mA, and has a viewing angle of 17 degrees. Refer to the HSDL-4220 and HSDL-4230 data sheets for more information on these products.

For 5 V systems, a parallel connection (Figure 9.1) may be used. The drive transistor of the HSDL-1001 has sufficient capacity to drive a second LED in parallel. The current in the external LED is limited by R_{LEDX} . The value of R_{LEDX} is chosen in the same manner as R_{LED} (refer to the section on *External Passive Components*). This configuration has the advantage of being less sensitive to power supply variations than the series connection, because more of the supply voltage is dropped across the limiting resistors.

The series, or “stacked” connection (Figure 9.2) can be used with supplies greater than 5 V. This connection is preferred because it uses power that would otherwise be wasted in R_{LED} . This configuration can be used when V_{CC} is high enough to allow for two forward voltage drops (2.5 V each at 240 mA) and the tolerance is tight enough so that the R_{LED} chosen for minimum V_{CC} does not cause excessive currents at maximum V_{CC} .

The combined intensity of the HSDL-1001 internal LED and the HSDL-4220 or HSDL-4230 external LED can be used to calculate the potential link distance. Link distance is proportional to the square root of the total intensity of the signal. Table 9.1 shows the typical link distances which can be achieved under typical operating conditions with various external LEDs driven as indicated. The values are based on a detector sensitivity of $4 \mu\text{W}/\text{cm}^2$.

For transceivers where an additional pin is not available to drive the LED in parallel as in the case of the HSDL-1001, the configuration given in Figure 9.3 can be used.

For data rates less than 115.2 kbps, transmitting signals with less than 20% duty cycle can help increase link distance. The receiver threshold is determined by average power, so a lower duty cycle will reduce average power and thus increase the receiver’s sensitivity. Also, to minimize power consumption and increase LED life, it is recommended to use the minimum pulse width allowed by IrDA, which is 1.6 μs .

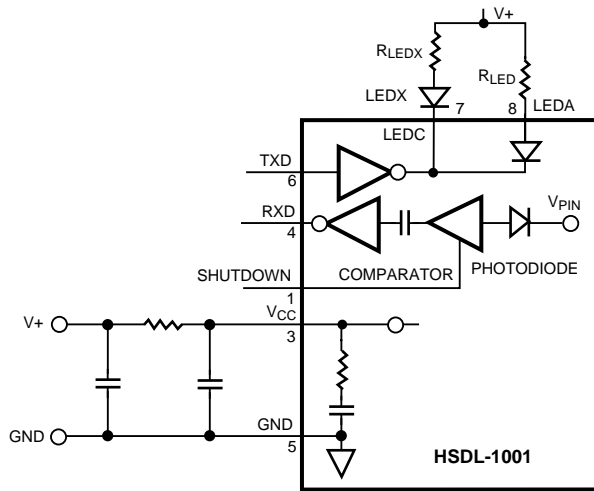

Figure 9.1 External Parallel LED.

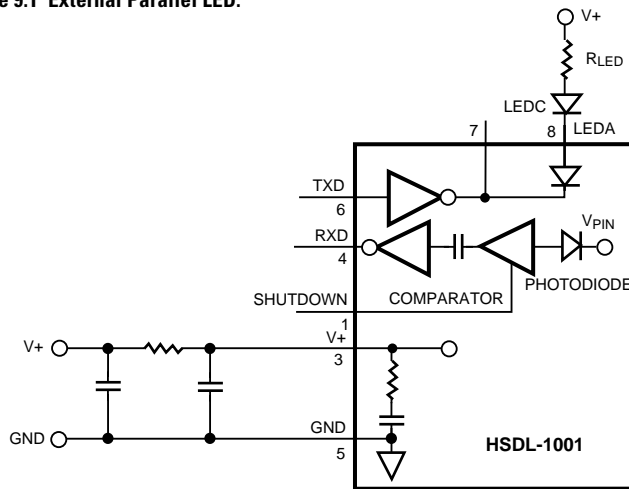

Figure 9.2 External Series LED.

Table 9.1 Link distances achievable for various transceiver and emitter combinations.

Transmitting Devices	LED Pulsed Drive Current (I_{peak}), mA	Total LED typical intensity on-axis, mW/Sr	Typical on-axis link distance, meters
HSDL-1001	250	100	1.6
HSDL-1001	500	200	2.2
HSDL-1001 and HSDL-4230	250 each	290	2.7
HSDL-1001 and HSDL-4230	500 each	950	4.9
HSDL-1001 and four HSDL-4230s	500 each	3200	8.9

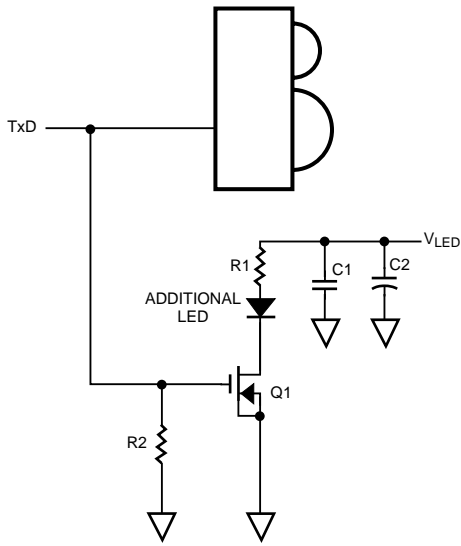

Figure 9.3 External Parallel LED with Switching Transistor.

9.2 REMOTE CONTROL APPLICATION

Before implementing Consumer IR (remote control) modes in IrDA enabled devices, it is essential to understand the differences in the current implementations of CIR and IrDA. Table 9.2 summarizes some of the key points.

In transmit only mode, the IrDA module is used to transmit in a CIR mode to a CIR receiver. The main influencing factor is the difference in operating wavelengths. Please refer to Figure 9.3. The operating wavelengths were set apart to reduce interference effects. This fact is important when using a CIR detector with an IR filter, where the link distance might be reduced based on the cut-off wavelength of the filter. This would lead to attenuation of the IR signal. IrDA is based on a base-band modulation scheme supporting data rates ranging from 2.4 to 115 kbps. This also encompasses the sub-carrier frequency of RC, which ranges from 30 – 70 kHz. Therefore modulation is not of concern.

Table 9.2: Differences between IrDA and RC

	IrDA	RC
Wavelength (nm)	850 – 900	900 – 950
Modulation	Baseband	ASK
Data Rate (kbps)	~ 115	~ 2
Link Distance (m)	~ 1 m	~ 8 m

In the receive mode, the RC modulation has a major role to play. An RC detector is tuned to detect RC sub-carrier frequencies. Therefore, an IrDA receiver will be less sensitive as compared to an RC detector at the RC operational point. Moreover, the IrDA transceiver was designed for a link distance of 1 m. In CIR mode, the link distance will come down to IrDA link distance levels. In most cases the IrDA module will be used in CIR transmit only mode as in PDAs and in a bi-directional mode.

TxD Interface

In the case of MPUs or ASICs that assign both IrDA and CIR transmit functions to the same pin, the connection is the same as in the IrDA case. If separate output driving pins are used, a logical OR gate should be used as shown in Figure 9.4. If the RC part uses a negative logic, an inverter should be used before the OR gate. In most cases, IrDA and RC functions are assigned to separate pins.

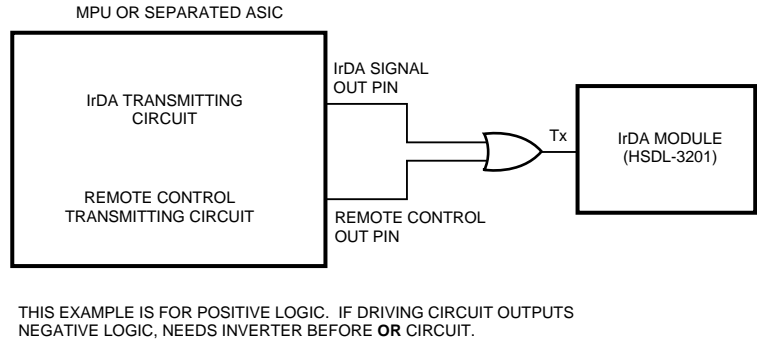

Figure 9.4 Circuit Example for Transmitting Mode.

RxD Interface

It is essential to remember the difference in sensitivity and the modulation scheme between IrDA and CIR when trying to use an IrDA transceiver in CIR mode.

Figure 9.5 shows an HSDL-3201 transceiver being used to implement CIR control. The transceiver outputs the raw data being received on the IR medium, as required by IrDA, and does not extract the baseband information required for CIR. Moreover, the pulse width is limited to 2.5 μ s for the HSDL-3201. CIR uses a much wider pulse width. Therefore, a monostable multivibrator (HC123) is used for pulse width widening. The value of the resistor and capacitor is chosen to match the sub-carrier frequency of CIR.

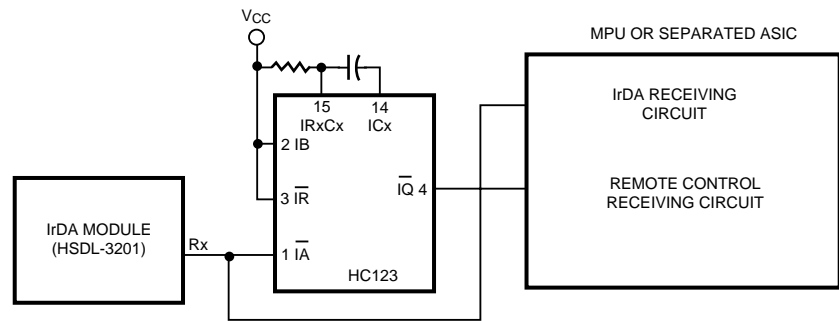

Figure 9.5 Circuit Example for Receiving Side.

10. Companion Circuits

Introduction

With ever-increasing functionality in handheld devices, IR transceivers are being coupled with discrete emitters and detectors, such as Agilent's HSDL-4xxx emitters and HSDL-5xxx detectors, to achieve higher link distances and to perform other IR functions not compliant with IrDA. The section, *Beyond IrDA*, explored such application scenarios and implementation. The following section highlights circuit configurations for driving discrete emitters and detectors. The echo cancellation circuit discussed below is used to nullify the signal seen by the receiver residing adjacent to the transmitter while the transmitter transmits in a transceiver.

10.1 LED DRIVER CIRCUITS

In many cases an additional LED is added to achieve an increase in light intensity and therefore link distance. The circuit below is a reference LED driver circuit using Agilent's HSDL-4230 emitter.

The switching transistor Q1 used is a Fairchild FET, Si4532DY or

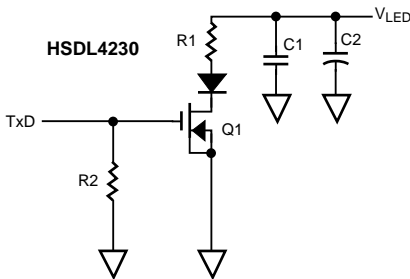

Figure 10.1 LED Driver Circuit.

NDS351. R1 determines the amount of current flowing through the LED and the capacitors C1 and C2 are for filtering the supply. R2 is a 50 ohm terminator in case of pulses being fed from a pulse generator that requires a 50 ohm termination. As an example, for a $V_{LED} = 3.2$ V, $R1 = 4.7$ ohms, transistor on resistance = 0.3 ohms and diode on resistance = 1.7 ohms, the LED current can be calculated to be around 250 mA. It can be seen from the data sheet that this translates to an intensity of 375 mW/Sr. With a $4 \mu\text{W}/\text{cm}^2$ detector, the link distance can be computed to 3 m.

10.2 RECEIVER CIRCUITS

Discrete detectors are used in many cases as additional sensors. The circuit configuration will consist of an I-V stage, gain and a comparator. A few of these variations are listed below.

Configuration A: Op-amp configuration using a combination of resistors and op-amps to realize the desired gain and comparator function.

Example values:

Detector HSDL-5420/5400, $R1 = 10$ k Ω (I-V gain stage), R2 and R3 (non-inverting gain), $R4 = 100$ k Ω , $R5 = 1$ k Ω , $C2 = 10$ pF. R4 and R5 define the hysteresis voltage.

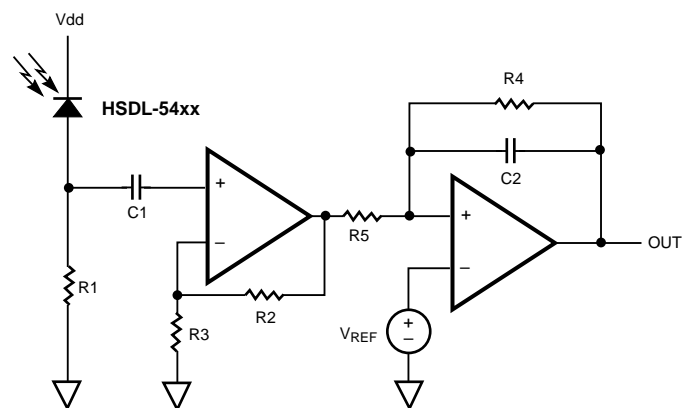

Figure 10.2 Receiver Circuit - Configuration A.

Configuration B: Op-amp, resistor and external comparator configuration. Op-amp and I-V resistor are used in the gain stage.

Example values:
 Detector HSDL-5420/5400,
 R1 = 10 kΩ (I-V gain stage),
 R2 and R3 (non-inverting gain).
 TLC3702 is a comparator without hysteresis.

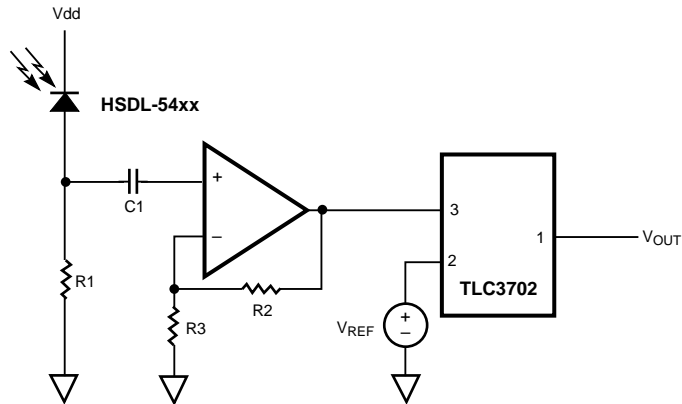

Figure 10.3 Receiver Circuit - Configuration B.

Configuration C: Resistor and comparator configuration. Gain is realized only from the I-V resistor stage.

Example values:
 Detector HSDL-5420/5400,
 R1 = 10 kΩ. TLC3702 is a comparator without hysteresis.

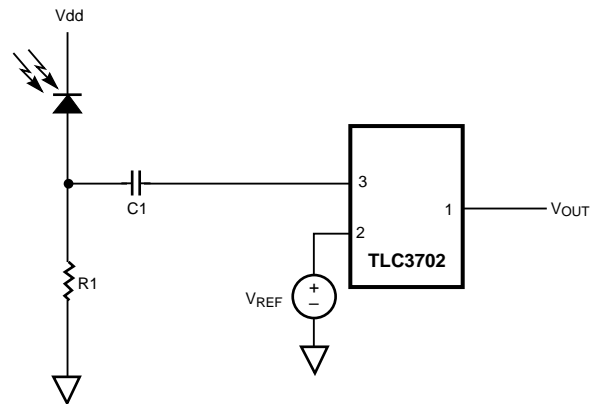

Figure 10.4 Receiver Circuit - Configuration C.

Some applications require a fixed pulse width pulse output during light incident. A configuration using a monostable multivibrator is shown in Figure 10.5 that achieves the same.

Configuration D: Monostable multivibrator configuration for single shot output stage.

SN74LS221 is a dual monostable multivibrator.

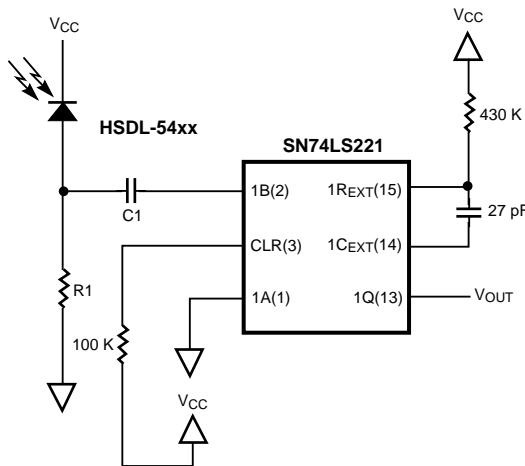

Figure 10.5 Receiver Circuit - Configuration D.

10.3 ECHO CANCELLATION CIRCUIT

The transceiver design is such that the receiver sees the transmitting light of the transmitter and generates an echo. This can be nullified by using an echo cancellation circuitry. Agilent transceivers inherently do not have an echo cancellation circuitry for the following reason. An echo of a transmitted pulse on the receiver side serves as a good self-check of the transmitter functionality. In the application, however, echoes on the receiver side while transmitting might cause hang-ups of the microcontroller. Generally, this is avoided by disabling all receiver interrupts while transmitting.

In the event that this must be implemented on hardware, the following reference circuit can be used. SN74LS221 is a monostable multivibrator, which generates a one shot pulse while transmitting. With the right choice of external components, this one shot pulse can be made to have the same pulse width as that of the echo seen by the receiver and therefore nullify it. However, it is always recommended to disable the receiver interrupts in the software while transmitting, as it is a less expensive and easier alternative.

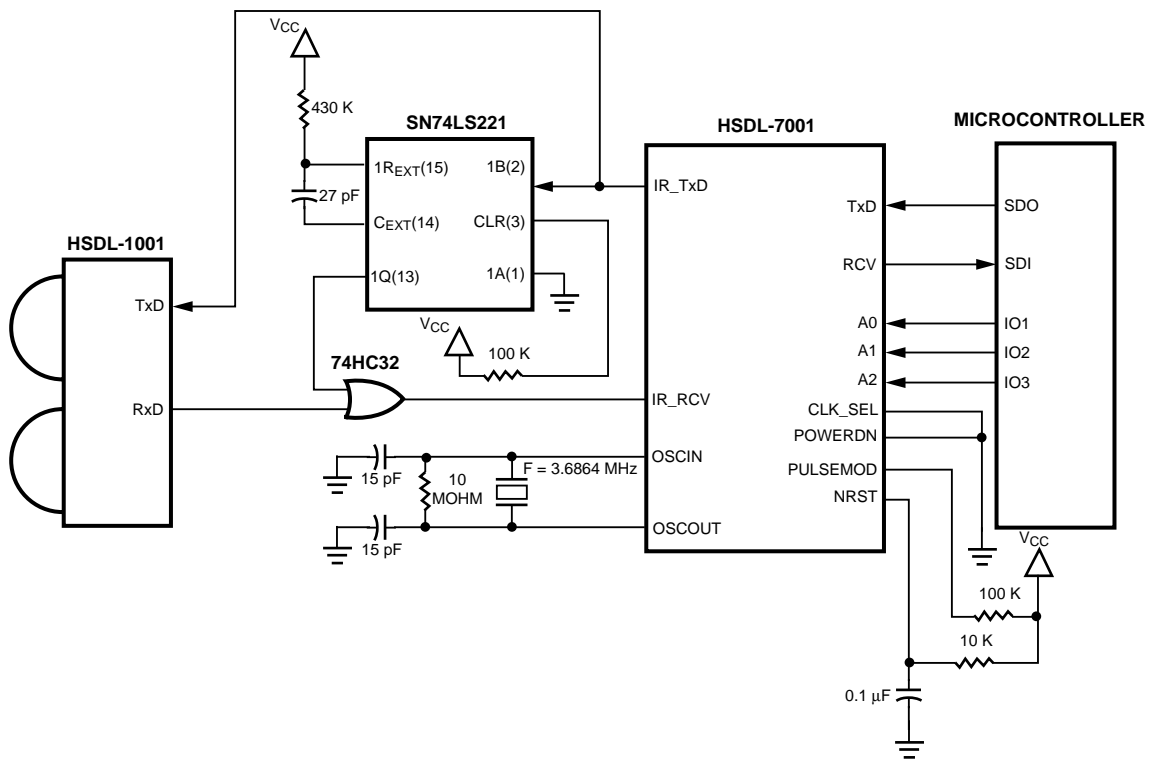

Figure 10.6 Echo Cancellation Circuit.

Appendix

Basic Radiometry

Definitions:

Radiant flux (ϕ):

Optical power emitted by a source in watts.

Radiant intensity ($IE = d\phi/d\Omega$):

Optical power emitted by a source within a cone of unit steradian.

Irradiance ($EI = d\phi/dA = dIE/dA$ for a point source): Optical power incident per unit area from a point source.

Steradian (ω): A steradian is the solid angle subtended from the center of a sphere by $1/4 \pi$ of the surface area of the sphere. There are 4π steradians in a full sphere. A cone of a solid angle ω , has its apex at the center of a sphere of radius R and defines an area A on the surface of the sphere. To find a solid angle (ω), determine the surface area of the sphere included within the solid angle (A), and divide the area by the square of the radius of the sphere (R).

$$\omega = A / R^2$$

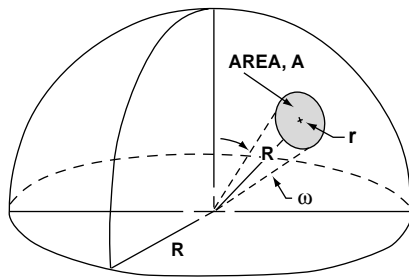

The radiant flux is the mean radiant energy transferred by the light radiation from a source and is the energy (or power, which is energy per unit time) quantity. For a point source of light, the radiant intensity describes the energy

transmitted in a unit solid angle, i.e., given the source angular width, the illumination can be estimated. The approximation that a transmitter LED source is a point source is valid except at very close distances of a few millimeters from the source.

The inverse square law describes the relationship between source radiant intensity and the irradiance at a distance.

$$EI = IE / d^2$$

Where IE is the transmitter radiant intensity, EI is the receiver input irradiance, and d is the distance between the transmitter and the receiver.

The inverse square law is useful in estimating the irradiance from the source intensity. Thus, a source of 500 mW/Sr at a distance of 50 cm results in an irradiance of 0.2 mW/cm^2 and at 1 m results in a radiance of 0.05 mW/cm^2 .

Integrating the irradiance over the effective detector area gives the radiant flux received by the detector. Multiplying the radiant flux by the receiver sensitivity yields the amount of detector photocurrent.

i.e., the detector photo current can be estimated from the irradiance as:

$$I_{\text{photo}} (\text{mA}) = \text{Irradiance} (EI \text{ mW/cm}^2) \cdot \text{effective detector area} (\text{cm}^2) \cdot \text{Detector sensitivity} (\text{mA/mW})$$

If a receiver lens were to be used to collect more light, then the detector area is either the physical detector area multiplied by the lens magnification **OR** the entrance pupil area of the lens (whichever is smaller). Quite often in the case of IrDA components, it is essentially the lens that defines the area of the receiver.

Example: Using a 2 mm diameter lens (lens effective area of 3.14 cm²) and a detector sensitivity of 0.5 mA/mW, see table A.1 below.

The I_{photo} calculated in Table A.1 is the pulsed photo current at the receiver for the respective transmitter intensity. The pulsed photo current should be more than the intrinsic noise level of the detector and the preamplifier electronics, for the signal to be detected.

Table A.1

SIR	Low power		Standard Power	
	Transmitter Intensity (mW/Sr)	3.6	72	40
Link Distance (cm)	20	20	100	100
Irradiance at receiver (mW/cm ²)	$3.6/400 = 0.009$	$72/400 = 0.18$	$40/10000 = 0.004$	$500/10000 = 0.05$
I_{photo} (μA)	$0.009 \cdot 3.14 \cdot 0.5 \cdot 1000 = 14.13$	$0.18 \cdot 3.14 \cdot 0.5 \cdot 1000 = 282.6$	$0.004 \cdot 3.14 \cdot 0.5 \cdot 1000 = 6.28 \mu\text{A}$	$0.05 \cdot 3.14 \cdot 0.5 \cdot 1000 = 78.5$

www.agilent.com/semiconductors

Data subject to change.

Copyright © 2003 Agilent Technologies, Inc.

March 26, 2003

Replaces 5965-1772EN

5988-9321EN



Agilent Technologies